

# SW10/19

## AUTOMATED PEDESTRIAN **SWINGING DOOR** OPERATOR

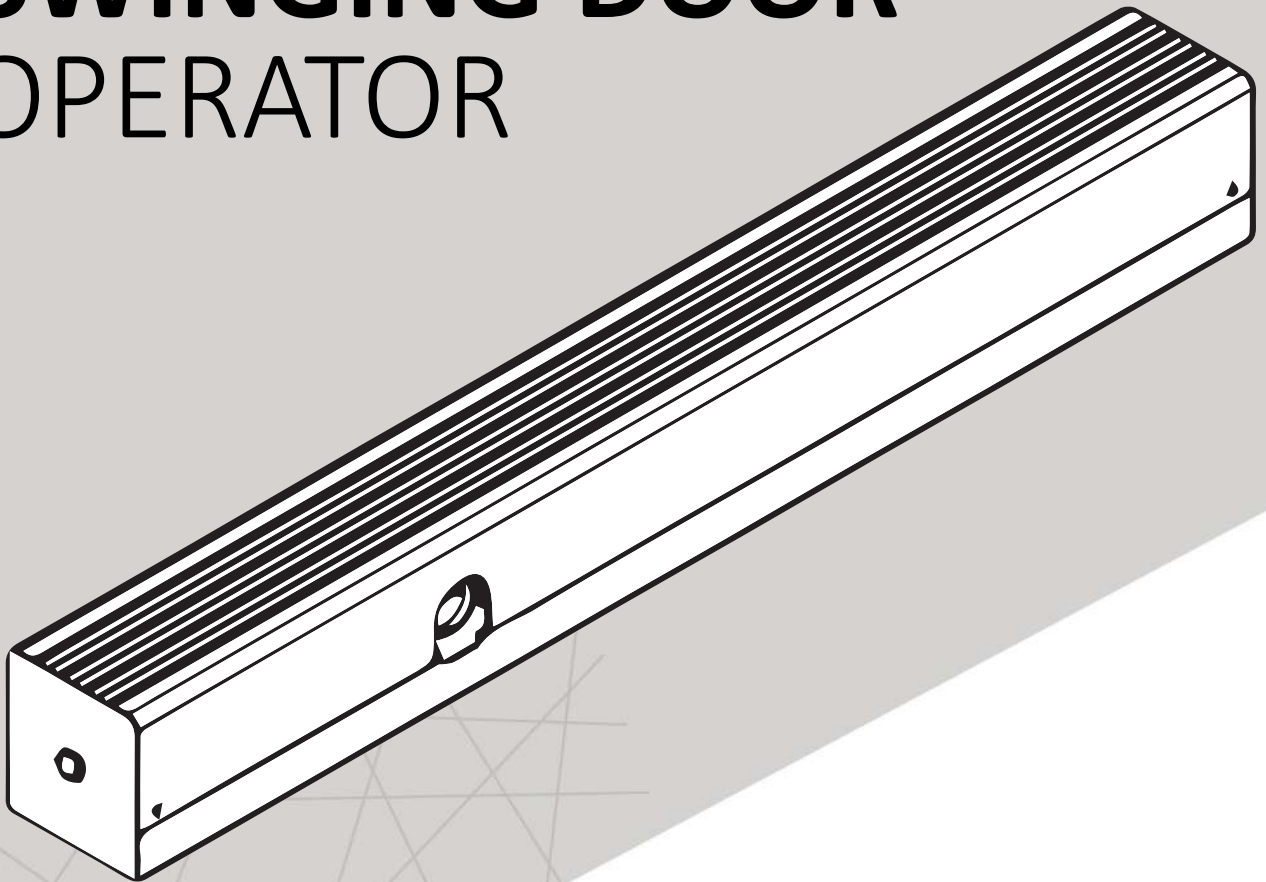

© COPYRIGHT



© Copyright PORTALP USA, Inc. from 2020. All rights reserved. No part of this manual may be reproduced, archived, distributed to third parties nor copied in any other way, in any format and with any means, be it electronic, mechanical or by photocopying, without prior written authorization by PORTALP USA, Inc. All names and trademarks mentioned are the property of their respective manufacturers. Customers may make copies exclusively for their own use. This manual was published in 2020.

*The data contained in this document are the property of PORTALP INTERNATIONAL and should not be changed without prior agreement of the manufacturer.*

*Les données contenues dans ce document sont la propriété de PORTALP INTERNATIONAL et ne doivent pas être modifiées sans l'accord préalable du fabricant.*

© Copyright PORTALP USA, Inc. depuis 2020. Tous droits réservés. Aucune partie de ce manuel ne peut être reproduite, archivée ou distribuée à des tiers ni copiée, sous tout format et avec tout moyen, qu'il soit électronique, mécanique ou par photocopie, sans le consentement écrit préalable de PORTALP USA, Inc. Tous les noms et les marques cités sont la propriété de leurs fabricants respectifs. Les clients peuvent faire des copies pour leur usage exclusif. Ce manuel a été publié en 2020.



**PORTALP, USA, Inc**

11075 Parker Drive  
Irwin, PA 15642

Tel: (412) 823-2537

Email: [sales@portalp.com](mailto:sales@portalp.com)

[www.portalp.com](http://www.portalp.com)

## TABLE OF CONTENTS:



---

04	<b>IMPORTANT NOTES</b>
05	<b>NOTES IMPORTANTES</b>
06	<b>PRODUCT DESCRIPTION &amp; SPECIFICATIONS</b>
07 - 13	<b>HEADER INSTALLATION</b>
14 - 17	<b>MOUNT THE OPERATOR(S)</b>
18 - 20	<b>PUSH ARM INSTALLATION</b>
21	<b>PULL ARM INSTALLATION</b>
22	<b>120 VOLT AC ELECTRICAL CONNECTION</b>
23	<b>POWER ON &amp; INDICATIONS</b>
24	<b>SET-UP PROCEDURES</b>
25	<b>SET THE DIP SWITCHES ON THE I/O BOARD</b>
26 - 27	<b>SET THE DIP SWITCHES ON THE ADJUSTMENT BOARD</b>
28	<b>WIRING CONNECTIONS</b>
29	<b>ADJUSTING THE MECHANICAL DOORSTOP</b>
30	<b>TROUBLESHOOTING</b>
31	<b>JOB DOCUMENTATION &amp; CLOSEOUT</b>
31	<b>ACCESSORIES</b>
31	<b>CUSTOMER SERVICE</b>

---

32 - 45	<b>APPENDIX - BOX CONTENT</b>
46 - 47	<b>APPENDIX - WIRING DIAGRAMS</b>
48	<b>APPENDIX - ELECTRIC LOCK APPLICATION</b>
49	<b>APPENDIX - SW10 PAIR WITH THE BAT + TORPEDO + BEA BODUGUARD</b>
50	<b>APPENDIX - SW10 SINGLE/PAIR WITH THE BAT + BEA LZR MICROSCAN</b>
51	<b>APPENDIX - SW10 SINGLE WITH THE BAT + BEA BODUGUARD</b>
52	<b>APPENDIX - FIRE RATED DOOR APPLICATION</b>
53	<b>APPENDIX - TAP PROGRAMMING DEVICE - KP evo</b>

## IMPORTANT NOTES



### READ THIS SECTION BEFORE PROCEEDING WITH INSTALLATION

PORTALP USA, Inc. recommends that all of its automated pedestrian door products be installed by a trained automatic door technician and that the resulting performance of the product be in full compliance with the most current version of the American National Standards Institute document A156.10 or A156.19 (whichever is applicable) as well as any applicable building codes and/or fire codes. PORTALP further recommends that a full inspection of the operating system be performed in accordance with the guidelines of the American Association of Automatic Door manufacturers (AAADM). This inspection must be performed by a certified AAADM trained inspector. PORTALP recommends this documented inspection be performed upon completion of the installation as well as, following the completion of every service call thereafter. If service is not performed within one year of the previous service action, a routine AAADM inspection should be performed and documented. Under no circumstance should the product operate for more than one year without an AAADM inspection. PORTALP does NOT recommend installation or service, on any of their automated pedestrian door products, by any individual who is not certified as an AAADM inspector.

Following the installation or service of any PORTALP automated pedestrian door product, if it is deemed unsafe, or is operating in an unsatisfactory manner according to national performance standards or recommended performance guidelines as defined by PORTALP, repairs should be made immediately. If an immediate repair cannot be made, the product should be disabled, and appropriate measures should be taken to secure the door in a safe position or to enable the door to safely be used manually. During this situation, every effort should be made to notify the owner (or person responsible) of the condition and to advise on corrective actions that must be taken to return the product to safe operation.

### LOW ENERGY APPLICATION NOTE

When using the SW10/19 for a low energy application, PORTALP recommends the use of a door-mounted presence sensor on the approach side of the door to be used as a secondary activation device. This type of sensor can be installed at time of installation or can also be retrofitted. This device serves to re-activate the door to the open position should a person enter the closing path at the approach side of the door, as it is closing. Once the door is fully closed, a "knowing act" device must then be used for initial activation. PORTALP considers this device to be essential in reducing the possibility of doors "timing out" and closing before all pedestrians have passed through the doorway.

*PORTALP USA, Inc reserves the right to change the presented products and materials without prior notice. Their description cannot on no account take on a contractual aspect.*

*The data contained in this document are the property of PORTALP INTERNATIONAL and should not be changed without prior agreement of the manufacturer.*

## NOTES IMPORTANTES



### READ THIS SECTION BEFORE PROCEEDING WITH INSTALLATION

**PORTALP USA, Inc** (ci-après dénommée “**PORTALP**”) préconise que tous ses produits relatifs aux portes piétonnes automatiques soient installés par un technicien de portes automatiques expérimenté et que la performance du produit qui en résultera soit tout à fait conforme à la version la plus actualisée du document A 156.10 ou 156.19 de l’Institut des Normes Nationales Américaines (en fonction de l’application), ainsi qu’aux codes du bâtiment et/ou codes de prévention des incendies applicables. PORTALP recommande qu’une inspection générale du système de fonctionnement soit effectuée conformément aux directives de l’Association Américaine des fabricants de Portes Automatiques (AAADM) et par un inspecteur qualifié agréé AAADM.

PORTALP préconise que cette inspection documentée soit réalisée dès l’achèvement de l’installation initiale, mais aussi à la fin de chaque appel de service ultérieur. Si aucune prestation de service n’a eu lieu durant une période d’un an depuis la date des derniers travaux de service, une inspection préventive AAADM devra être effectuée et documentée. Sous aucune condition, le produit peut-il être en fonctionnement pour plus d’un an sans inspection. AAADM. PORTALP ne recommande NI l’installation NI le service d’entretien sur aucun de leurs produits de portes piétonnes automatisées par une personne autre qu’un inspecteur AAADM agréé. Après l’installation ou la prestation de service des portes piétonnes automatisées, si celles-ci sont jugées non sécurisées ou ne fonctionnent pas de manière satisfaisante conformément aux normes d’opération nationales ou aux directives d’opération définies par PORTALP, il faudra procéder aux réparations nécessaires dans les plus brefs délais. Si une réparation immédiate ne peut se faire, le produit doit être désactivé et des mesures appropriées doivent être prises afin de sécuriser la porte ou de permettre à celle-ci de pouvoir être utilisée manuellement en toute sécurité. Dans tel cas, tous les efforts devront être entrepris afin de signaler le problème au propriétaire (ou à la personne responsable) et de lui fournir les renseignements nécessaires afin de corriger la situation et rétablir le bon fonctionnement du produit.

### REMARQUE SUR L’APPLICATION À ÉNERGIE FAIBLE

Lors de l’utilisation du SW10 / 19 en présence d’application à énergie faible, PORTALP préconise l’utilisation d’un avertisseur de présence monté sur porte côté non battant en guise de dispositif d’activation secondaire. Ce type d’avertisseur peut être installé ou faire l’objet d’une actualisation. Ce dispositif sert à réactiver la porte dans sa position ouverte au cas où une personne entrerait dans le parcours de fermeture du côté non battant pendant que la porte se ferme. Lors de la fermeture complète de la porte, un dispositif d’action délibérée doit être utilisé pour l’activation initiale. Tucker considère ce dernier comme essentiel afin de minimiser les éventualités de temporisation et les risques que les portes ne se ferment avant de permettre l’achèvement de la circulation piétonne dans la voie de passage.

*PORTALP USA, Inc. se réserve le droit de modifier les produits et matériaux présentés sans préavis. Leur description ne peut en aucun cas prendre un aspect contractuel.*

*Les données contenues dans ce document sont la propriété de PORTALP INTERNATIONAL et ne doivent pas être modifiées sans l’accord préalable du fabricant.*

# PRODUCT DESCRIPTION & SPECIFICATIONS



Power Supply*	115 VAC (+6%, -10%) 60Hz with ground	
Power Consumption	100W	
Current Consumption	1A	
Motor	24 VDC Permanent Magnet with Belt Driven Encoder	
Header Dimensions	4 <sup>1</sup> / <sub>2</sub> " Height x 4 <sup>7</sup> / <sub>8</sub> " Depth	
Fused Protection	3.5A Fuse (F1 located on I/O Board)	
Weight	32 lbs – 65 lbs Per Operator Assembly	
Ambient Operating Temperature**	-4 to 131° F	
Ingress Protection	IP23 (protection from spray water up to 60° from the vertical - ie. Rainstorm)	
Maximum Door Weight	<b>PUSH ARM</b>	<b>PULL ARM</b>
	36" Door: 438 lbs	342 lbs
	42" Door: 328 lbs	256 lbs
	44" Door: 299 lbs	234 lbs
	48" Door: 254 lbs	198 lbs
24 VDC Accessories Power Supply	24 VDC / I A. Max	
24 VDC Electric Lock Power Supply	24 VDC / I A. Max	
Adjustable Speeds & Timers	Opening Speed, Closing Speed, Hold Open Time, Closing Speed with power off	
Standard Selector Switch Functions	Automatic, Hold Open, Manual (Off)	
Standard Control Outputs	<ul style="list-style-type: none"> <li>Malfunction Alarm Signal</li> <li>Electric Lock Relay</li> <li>24 VDC Accessories Power Supply</li> <li>Door Status</li> </ul>	
Standard Control Inputs	Interior Activation, Exterior Activation, Emergency Shutdown, Alarm Output, "Stop" Safety Device (door-mounted), Safety Device Input, Secondary Activation	
Quick Disconnects	TAP-Controller (optional)	

\* This product should only be connected to an electrical installation that complies with the regulations.

\*\* The installer must ensure that the temperature range marked on the nameplate is well suited to the site.



Before any work is carried out, please comply with the size (width, weight) specified in the Technical Characteristics. If instructions are not followed, this may seriously affect the function of the operator. The manufacturer is not responsible if the operator is used outside of the scope of its application or contrary to the assembly instructions.

Avant tout travail, veuillez respecter les dimensions (largeur, poids) spécifiées dans les caractéristiques techniques. Si les instructions ne sont pas respectées, cela peut affecter gravement le fonctionnement de l'opérateur. Le fabricant n'est pas responsable si l'opérateur est utilisé en dehors du domaine d'application de son application ou contrairement aux instructions de montage.

## HEADER INSTALLATION



Mount the pre-drilled back-plate to the top door frame using appropriate fasteners for the type of frame.  
(Refer to Door Prep drawings on pgs. 8-13.)

- Push side mounting: Pre-drilled back-plate is flush with bottom of door frame.
- Pull side mounting: Pre-drilled back-plate is mounted 1.5" up from bottom door frame.
- Back-plate should overlap each jamb tube by 1.5".
- Refer to the **APPENDIX** for fire rated door applications.

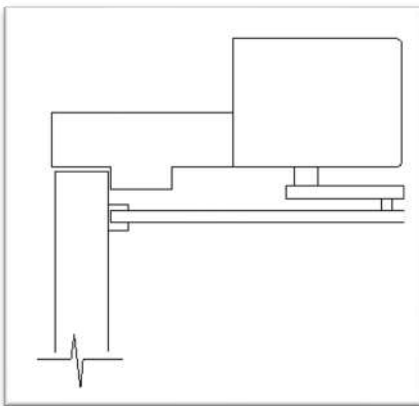

### PUSH ARM APPLICATIONS:

Bottom of swing unit is flush with bottom of top door frame.

### NOTE:

PORTALP is now using a 35mm spindle adaptor for all standard push arm applications – this requires that the header assembly be mounted as shown at left, flush with bottom of top door frame.

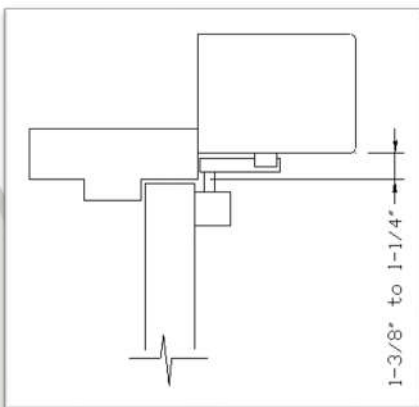

### PULL ARM APPLICATION: STANDARD PULL ARM & DOUBLE EGRESS APPLICATIONS

Double egress applications require the use of an 80mm spindle adaptor for the side using the push arm.

# HEADER INSTALLATION



**PUSH SIDE INSTALLATION SINGLE | DOOR PREP DRAWINGS**

**NOTE:** Hollow metal frame with 5/8" stop height shown.

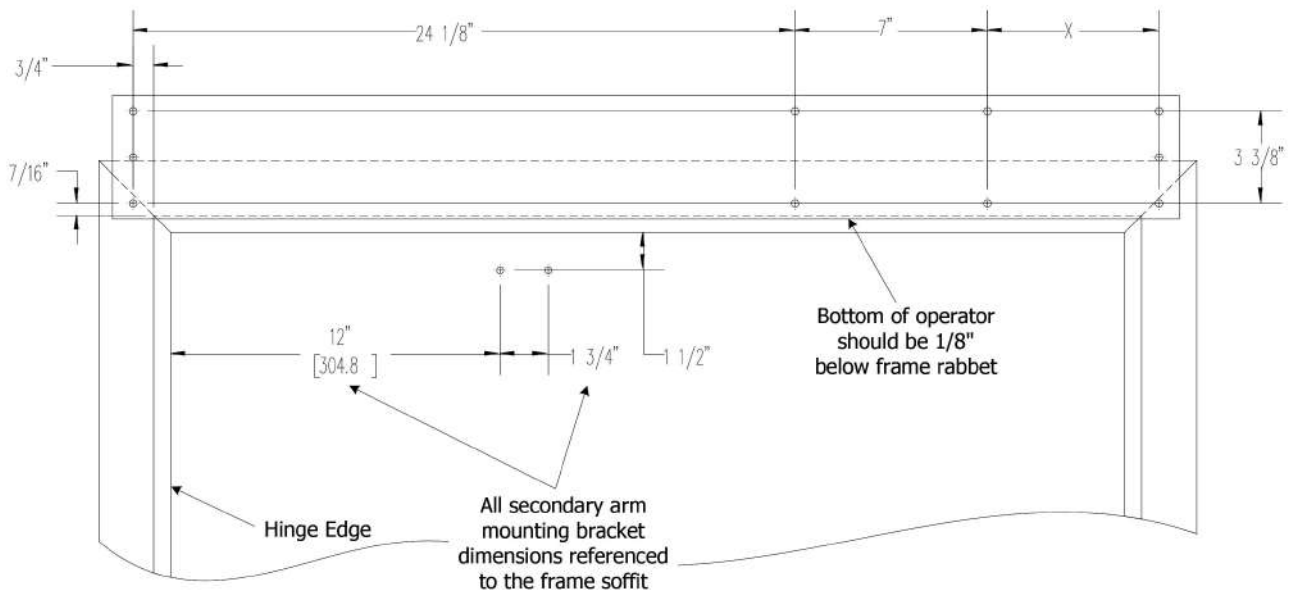

Opening Width	Operator Width	X Dim
36"	39"	6.25"
42"	45"	12.25"
44"	47"	14.25"
48"	51"	18.25"



# HEADER INSTALLATION



**PUSH SIDE INSTALLATION DOUBLE | DOOR PREP DRAWINGS**

**NOTES:**

Hollow metal frame with 5/8" stop height shown.

"A" dimension is only located on the 72" & 96" operator.

"B" & "C" dimensions are only located on the 84", 88" and 96" operators.

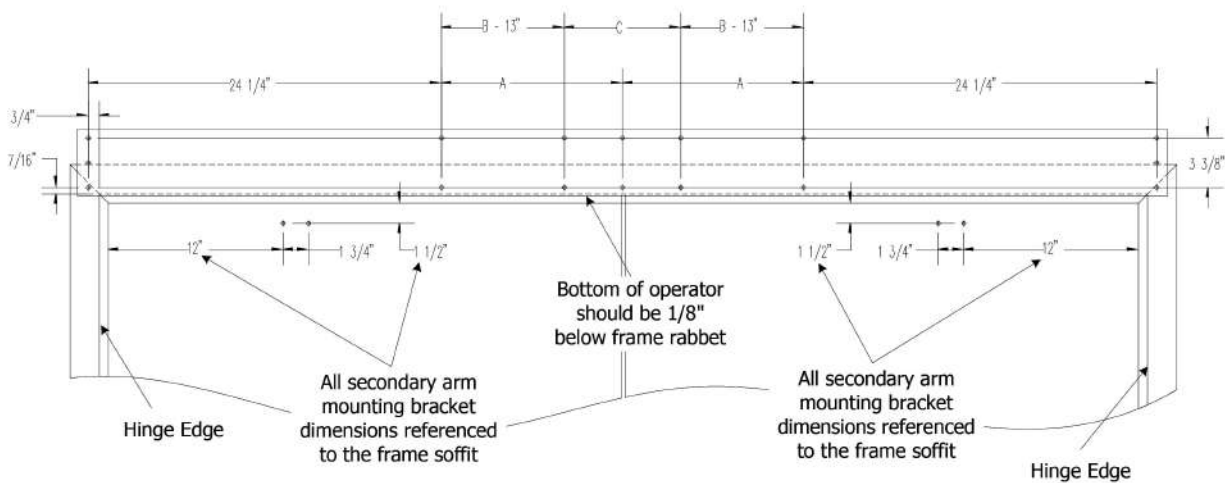

Opening Width	Operator Width	A Dim	C Dim
72"	75"	12-7/16"	N/A
84"	87"	N/A	10-7/8"
88"	91"	N/A	14-7/8"
96"	99"	24-7/16"	22-7/8"

# HEADER INSTALLATION



■ **PULL SIDE INSTALLATION SINGLE** | DOOR PREP DRAWINGS

**NOTE:** Hollow metal frame with 5/8" stop height shown.

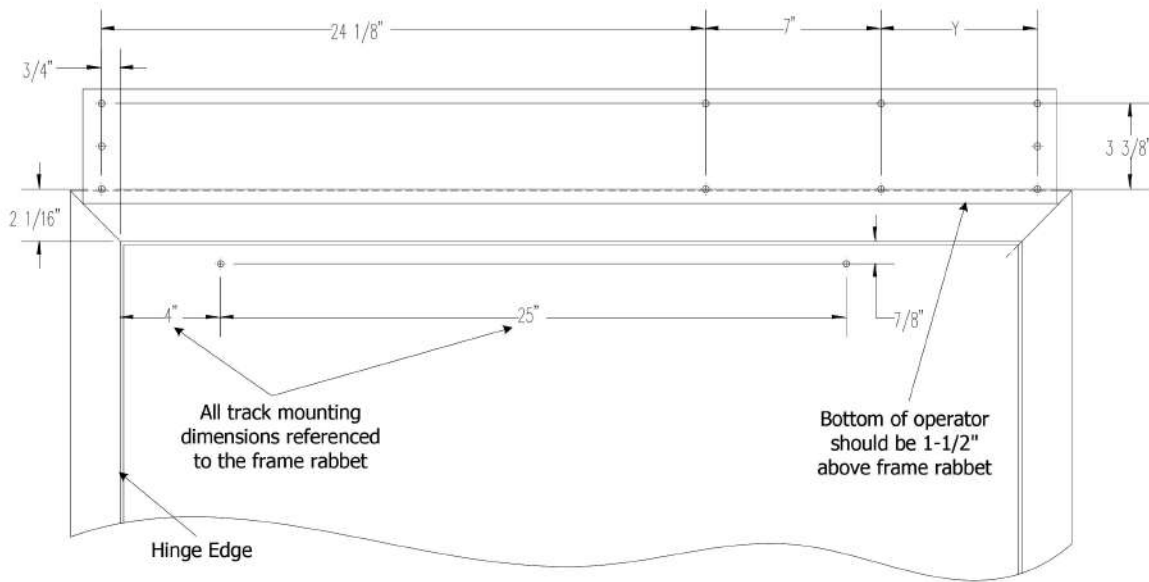

Opening Width	Operator Width	Y Dim
36"	39"	6.25"
42"	45"	12.25"
44"	47"	14.25"
48"	51"	18.25"

# HEADER INSTALLATION



■ **PULL SIDE INSTALLATION DOUBLE** | DOOR PREP DRAWINGS

**NOTES:**

Hollow metal frame with 5/8" stop height shown.

"A" dimension is only located on the 72" & 96" operator.

"B" & "C" dimensions are only located on the 84", 88" and 96" operators.

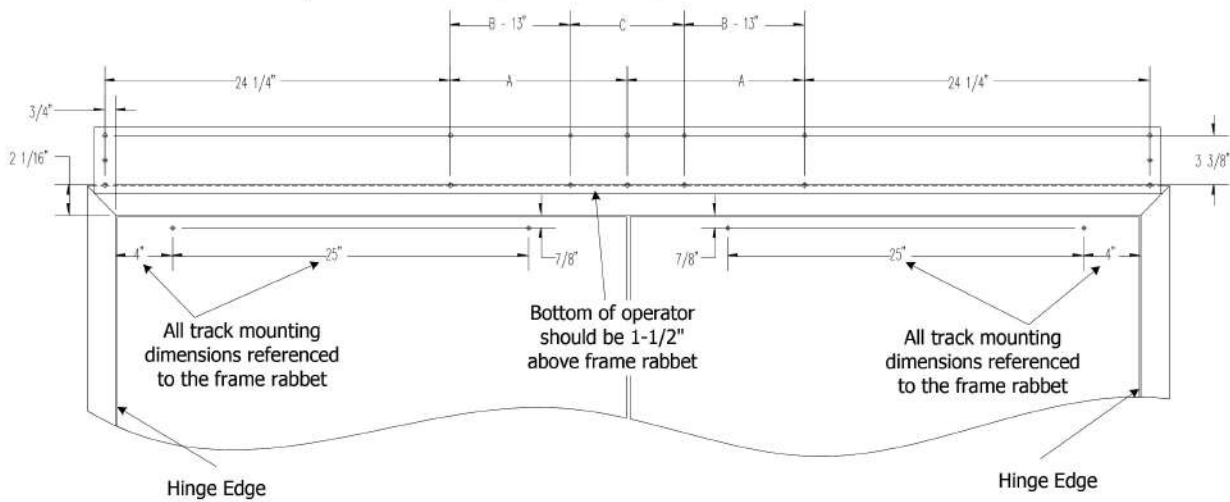

Opening Width	Operator Width	A Dim	C Dim
72"	75"	12-7/16"	N/A
84"	87"	N/A	10-7/8"
88"	91"	N/A	14-7/8"
96"	99"	24-7/16"	22-7/8"

# HEADER INSTALLATION



■ **DOUBLE EGRESS INSTALLATION | DOOR PREP DRAWINGS**

**NOTES:**

Hollow metal frame with 5/8" stop height shown.

"A" dimension is only located on the 72" & 96" operator.

"B" & "C" dimensions are only located on the 84", 88" and 96" operators.

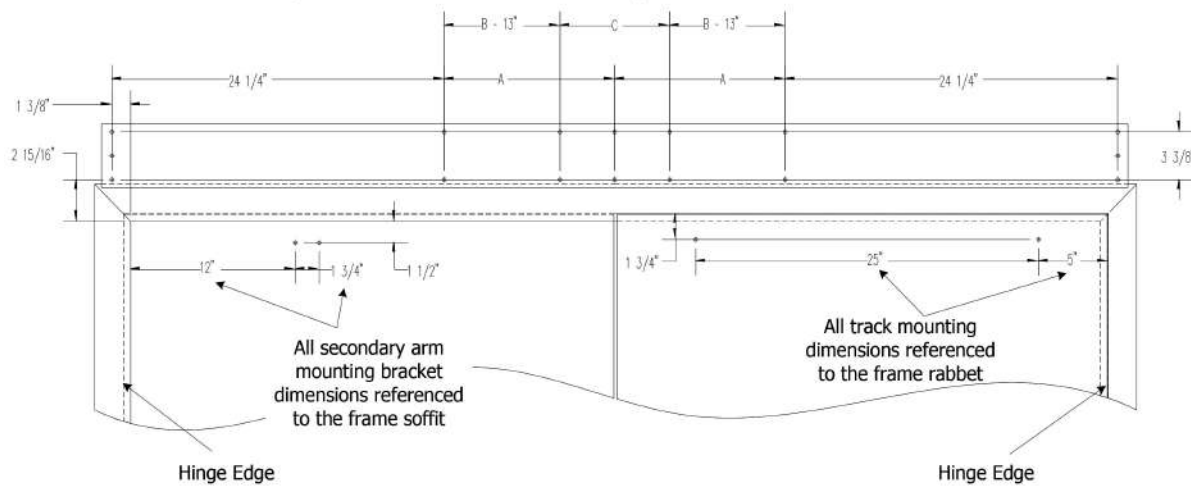

Opening Width	Operator Width	A Dim	C Dim
72"	75"	12-7/16"	N/A
84"	87"	N/A	10-7/8"
88"	91"	N/A	14-7/8"
96"	99"	24-7/16"	22-7/8"

# HEADER INSTALLATION



**NOTES:**  
Hollow metal frame with 5/8" stop height shown.

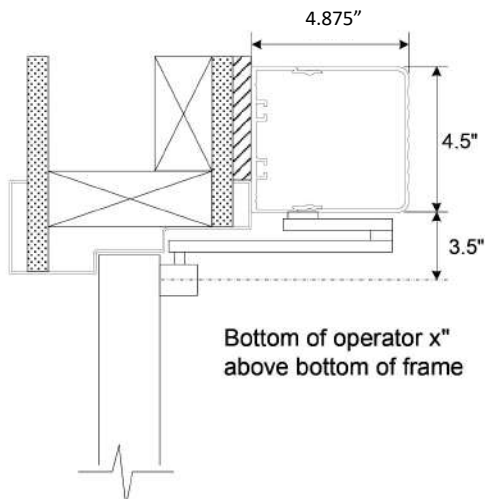

**DOUBLE EGRESS PULL ARM**

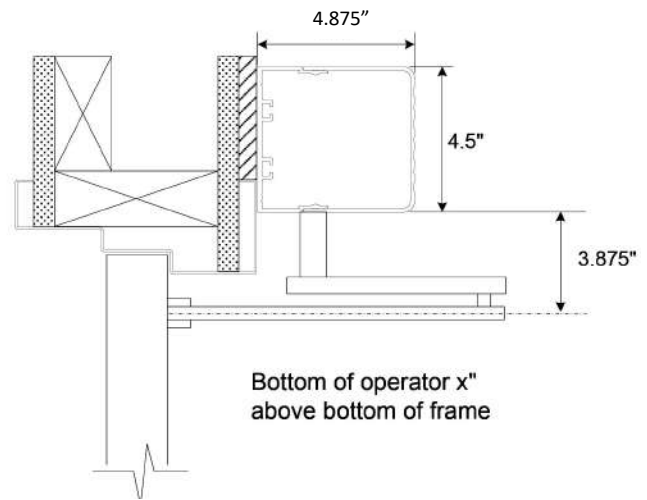

**DOUBLE EGRESS PUSH ARM**

## MOUNT THE OPERATOR(S)



- Operator is non-handed – same operator for all hands of doors
- Handing is determined by how the operator is mounted inside the header
- The operator is mounted to a short aluminum “drive” plate that is held into the header by 5 mounting screws. Four (4) of the screws secure the drive plate. One (1) screw is used to locate the drive plate using a ‘keyhole’ configuration. The keyhole allows for easy removal of the drive plate without the need to loosen the screw. Removing the four (4) screws allows the drive plate & operator to be removed from the header and rotated 180 degrees to change from a push to a pull or vice versa.

1

Drive Plate mounted in standard position using four (4) screws to secure. Loosen the screws using a 5 mm allen wrench and slide each one off the drive plate.

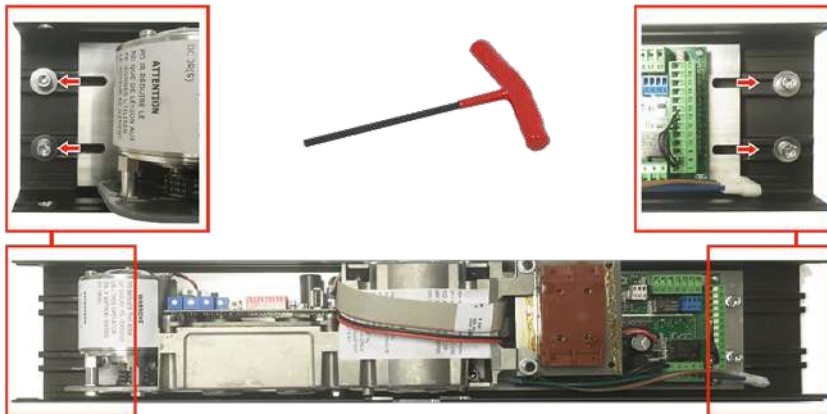

2

Drive plate removed by shifting to the left and lifting the drive plate off the locating screw.

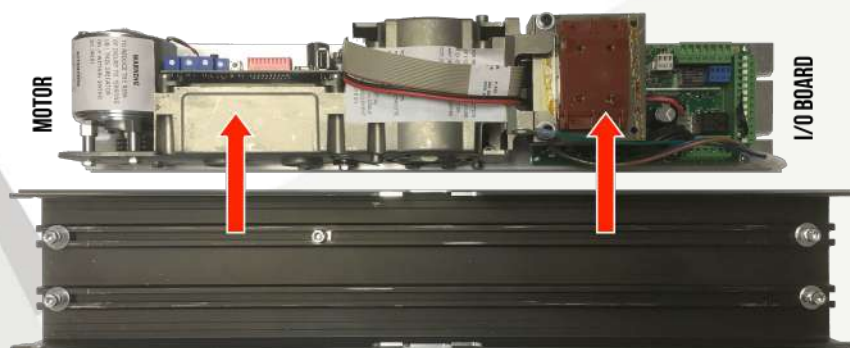



## MOUNT THE OPERATOR(S)

3

For pull application the motor should be located near the hinge side of the door.  
 For push application the I/O board should be located near the hinge side of the door.  
 Re-align locating screw to key slot, insert drive plate and shift to the right into position.  
 Re-position the four (4) screws to secure the drive plate.

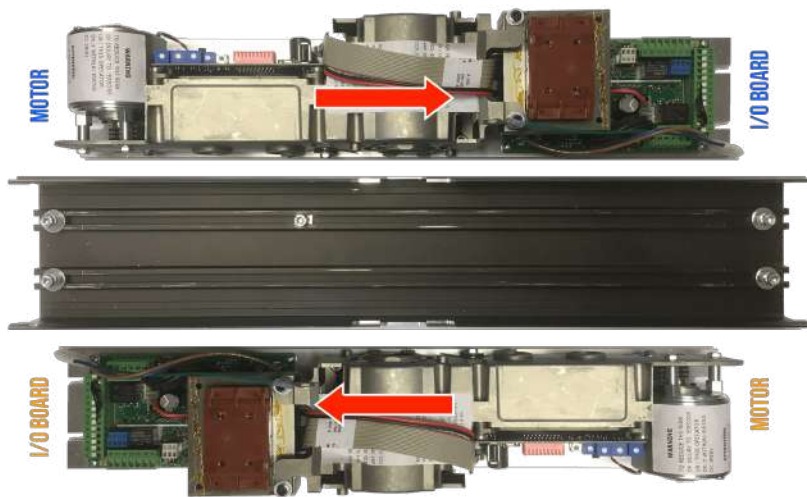

4

Key slot configuration & location screw mounted in backplate.

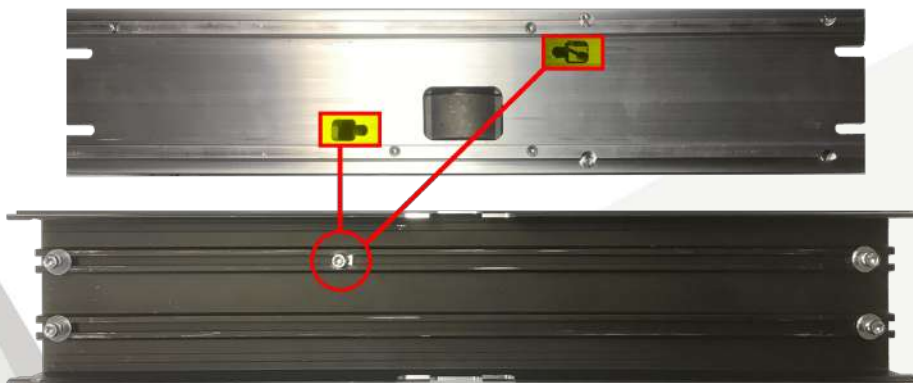

# MOUNT THE OPERATOR(S)

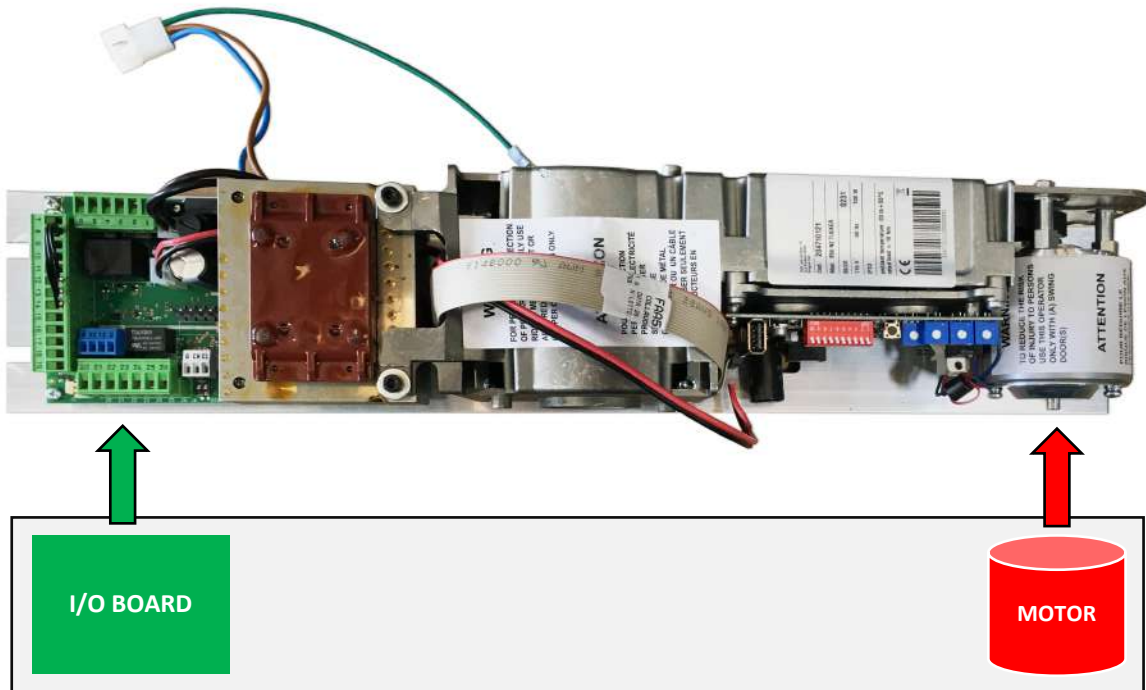

**PUSH = I/O BOARD IS TOWARDS THE HINGE JAMB**

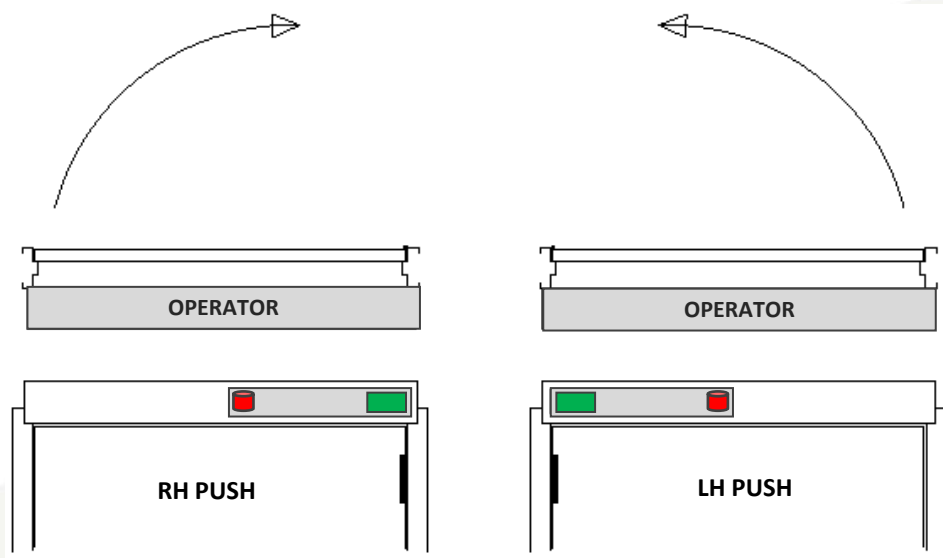



# MOUNT THE OPERATOR(S)



**PULL = ROUND MOTOR IS TOWARDS THE HINGE**

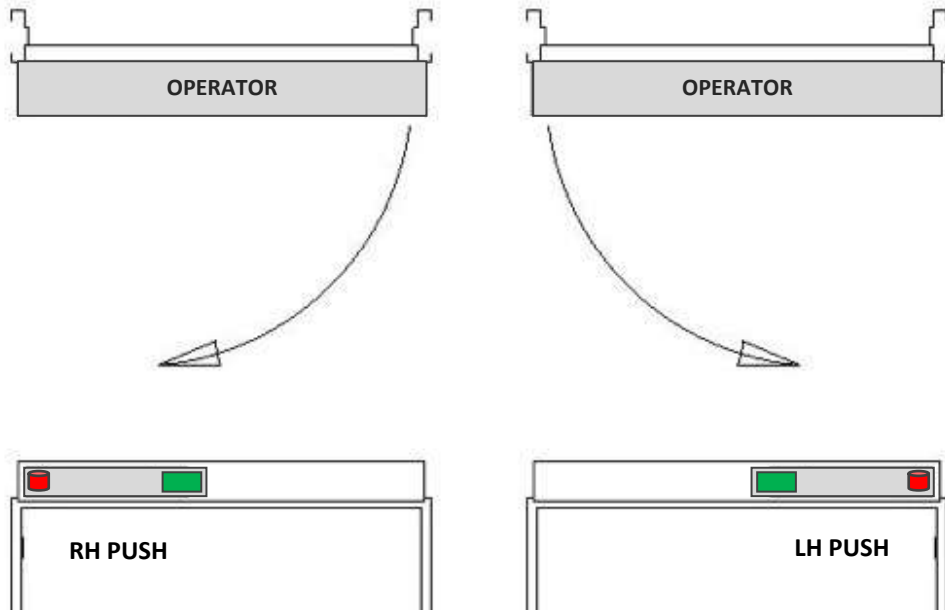

- Mount the header to the doorframe with the screws provided.
- The header will overlap the doorframe by 1-1/2" at each side.

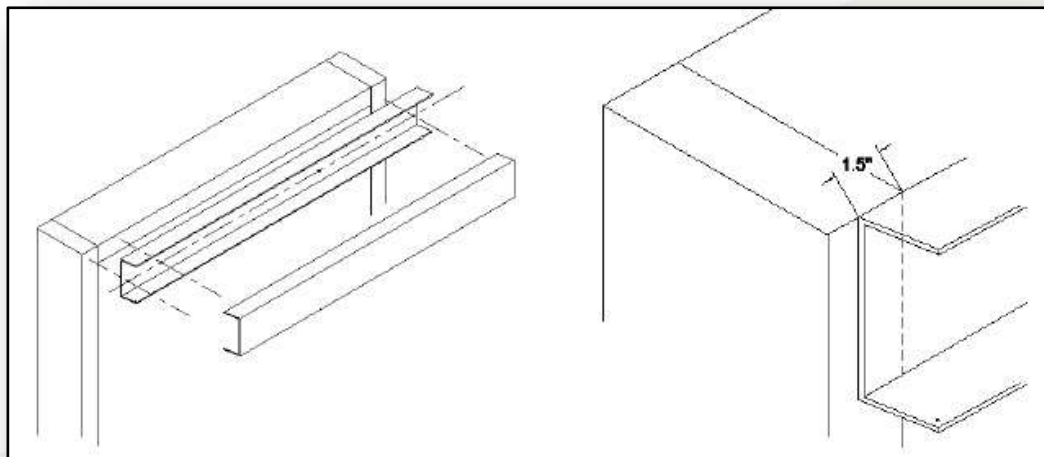

# PUSH ARM INSTALLATION



All push arms come standard with 35mm spindle. 50mm and 80mm available as an accessory.

([BOX CONTENT](#) - Page 33 - 35)

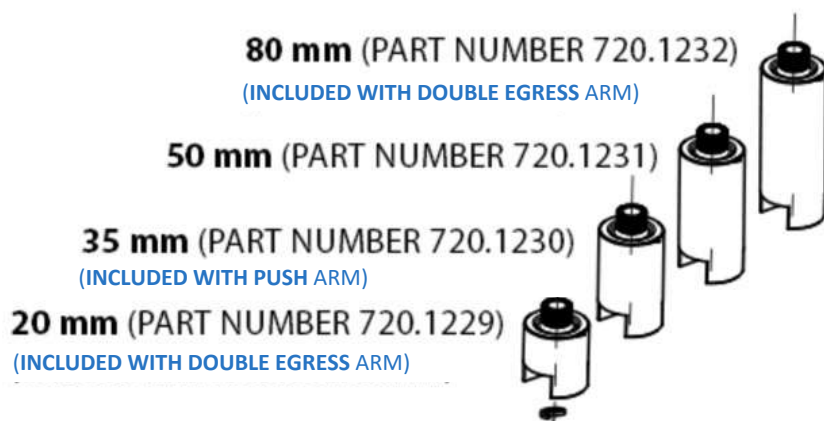

Attach the primary door arm approx. 20 degrees past perpendicular and towards the closing direction as shown. If more spring tension is desired, simply increase the mounting angle to greater than 20 degrees so it results in increased preload.

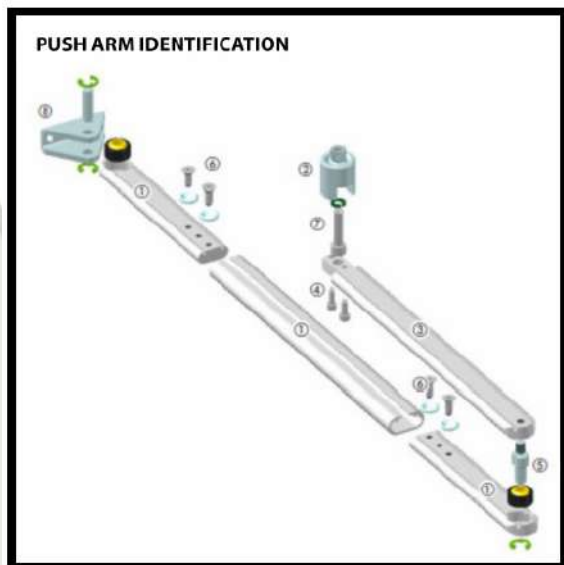

([BOX CONTENT](#) - Page 33 - 35)

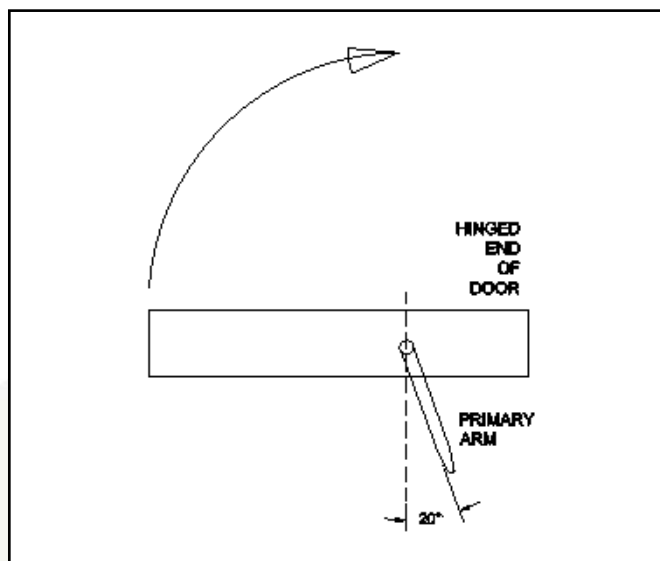



# PUSH ARM INSTALLATION

Adjust the secondary telescopic arm to the prescribed length according to chart:

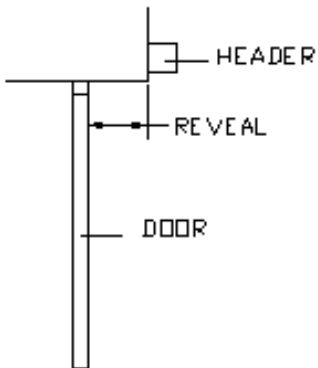

Reveal	Hinge Hung X Dim.	Center Pivot X Dim.
0"	13"	16"
1"	14"	17"
2"	15"	18"
3"	16"	19"
4"	17"	20"
5"	18"	21"
6"	19"	
7"	20"	
8"	21"	

**DEEPER REVEAL REQUIRES ARM EXTENSION**

Before installing any portion of the door arm assembly, it is easiest to lay the arm out on a flat surface and insert the secondary and primary arm into the sleeve as it will be when installed on the door:

- Slide the short arms within the sleeve to obtain the prescribed "X" dimension.
- Tighten the screws on the short arm that is connected to the door shoe.
- Double-check the "X" dimension of the arm - this is the distance between the center of the hole at the door shoe and the center of the hole at the pivot point of the primary arm (as shown).
- Mark a pencil line at the edge of the sleeve where it overlaps the short arm that is connected to the primary arm. This will make it easier when positioning the primary arm for final installation.

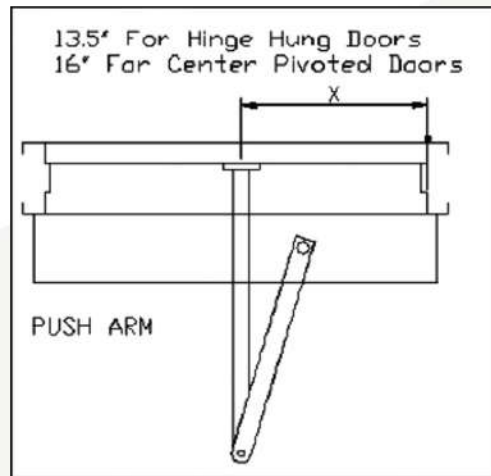
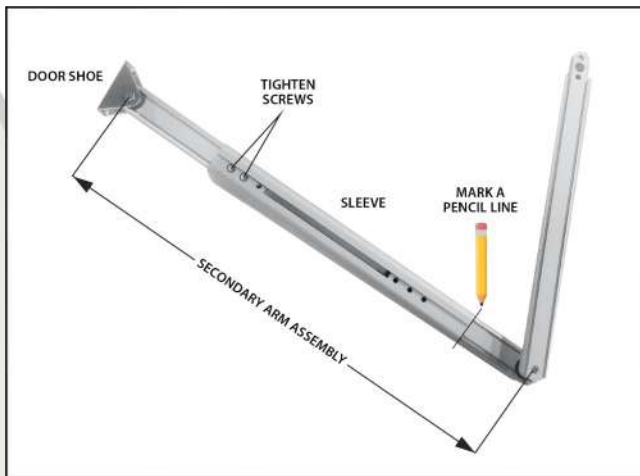

Attach the secondary arm mounting bracket to the door. The centerline of the bracket should be at 13-1/2" in from the inside face of the hinge jamb when using butt hinges on the door, and 16" when using a center pivoted door.

# PUSH ARM INSTALLATION



Rotate the primary arm in the opening direction as to reach the pivot point of the secondary.  
Attach the arms together with the hardware provided.

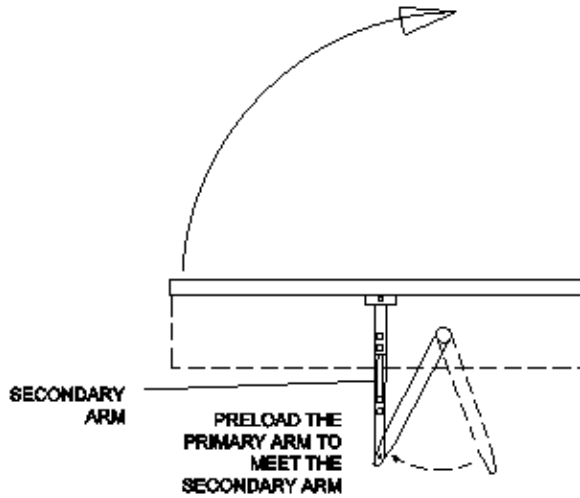



# PULL ARM INSTALLATION

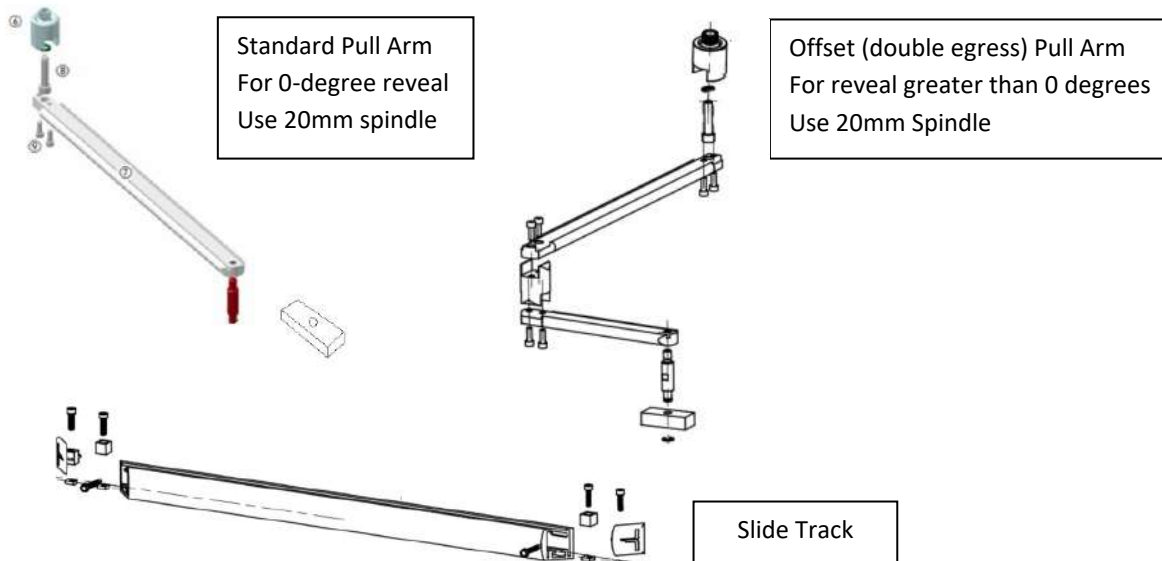

Install the slide track assembly at the pull side of the door at the proper location from the hinge end of the door as shown below:

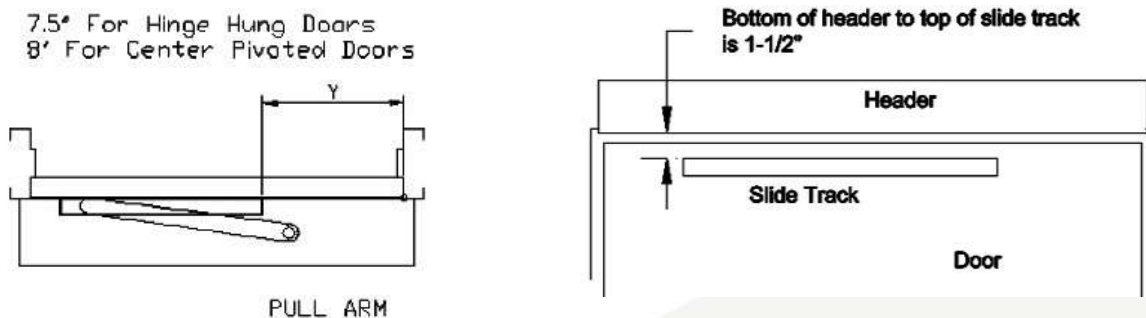

To install the pull arm, and allow proper preload the operator must be powered to the fully open position.

Power the door to the open position through the use of the hold-open switch on the side of the header. It may be necessary to first execute a "setup" on the operator prior to doing this. Refer to the applicable section within this User's Guide for proper instruction.

Once the operator is rotated to the fully open position, manually move the door to the desired fully open position and insert the slide track guide block into the track. When completed, the end caps to the track can be installed.

## 120 VOLT AC ELECTRICAL CONNECTION



**WARNING:** Ensure all incoming electrical power is shut off before proceeding with any wiring to SW10/19. Use only with wire harness provided; failure to do so may result in damage to equipment or personal harm as well as voiding the warranty.

**AVERTISSEMENT:** assurez-vous que toute alimentation électrique entrante est coupée avant de procéder au câblage du SW10/19. À utiliser uniquement avec le faisceau de câbles fourni; le non-respect de cette consigne peut entraîner des dommages matériels ou corporels ainsi que l'annulation de la garantie.

Connect the main power to the Black / White / Green connector on the back-plate.

- Main power supply: 120 VAC, 15A, Single Phase, 60 Hz. circuit
- Attach the incoming 120 volt AC line wires to the wiring provided in the header – as shown below.

**DO NOT TURN POWER ON** until all remaining wiring has been completed.

**BLACK:** 115 VAC Power  
**WHITE:** Neutral  
**GREEN:** Ground

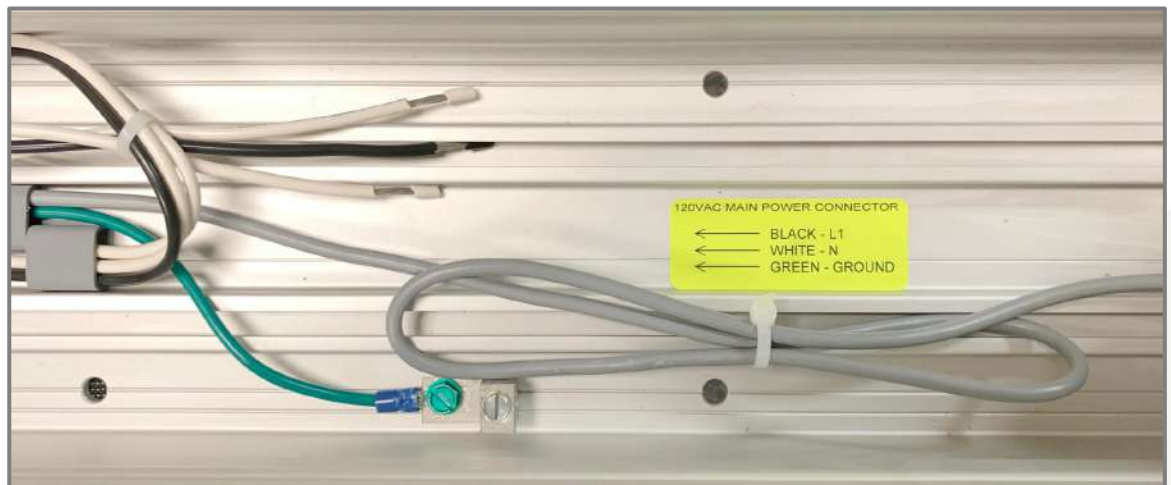



## POWER ON & INDICATIONS



- DL1 : **GREEN** USB CONNECTION
- DL2: FLASHING **RED** LED
- DL3: **BLUE** 5V POWER SUPPLY
- DL4: BOARD VALUES DIFFER FROM DIP SWITCHES  
(PRESS SW1 MOMENTARILY TO EXTINGUISH YELLOW LED)

Upon applying power, observe the above LED's.

**NORMAL OPERATION:** DL3 will come on steady and then begin flashing after a few seconds.

**FAULTY OPERATION;** DL2 will be flashing **RED**. This indicates...

- An error condition exists – correct as necessary
- Operator requires setup – launch a setup and proceed accordingly

**NOTE:** DL4 will illuminate yellow anytime a change has been made to the control, such as a speed or time adjustment. Momentarily press on SW1 to acknowledge the change and extinguish the yellow LED.



### HELPFUL NOTES:

- Speed and time adjustment changes will not take effect until the door closes fully after the adjustment has been made.
- Hold Open time affects the delay following activation from input 10, 11, and 13.
- When Dip Switch 5 is ON, the blue speed and time potentiometers are disabled and will have no effect.

## SET-UP PROCEDURES



Perform a setup at the control as follows:

- Ensure main power is on
- At the I/O control board, depress the SW1 button for approximately 5 seconds. When the red LED (LD2) at the Adjustment Board begins flashing rapidly, release the button. The blue LED will continue flashing.
- Door will slowly go open, recycle partially, close and then re-open.
- **Do not interrupt the process and do not move the door manually during this time.**
- If the door does not open and the red LED (DL2) is flashing slowly, check to make sure the motor is plugged in properly at the control board. Correct as necessary.
- Once the setup process is complete, the door will close and the LED will go out.
- Setup is complete.



**IMPORTANT NOTE:** If the operator stroke is altered in any way, a re-learn must be accomplished.

- Upon completion of the Setup, activate the door to open and ensure all performance is acceptable.
- Adjust opening and closing speed, as necessary. If speeds are changed, a re-learn is not required.
- A re-learn is not required following a main power recovery.
- Adjust hold-open time as required.
- Additional adjustments are available through the TAP.

- B1** – Battery – use CR1216 battery – required to maintain timer settings and date programmed by the TAP
- TR1** – Opening speed adjustment
- TR2** – Closing speed adjustment
- TR3** – Hold-open time adjustment
- TR4** – Closing speed adjustment when power is OFF **TR4** will only be enabled when jumper **J6** is moved to the correct pins. (it is enabled by default).
- J2** – USB port
- J4** – Ribbon cable connector between boards
- J5** – Motor Connector
- J7** – Power supply connector between boards
- SW1** – “Parameter Changed” button
- SW2** – 10 Position “Functions” Dip Switch  
For adjustments beyond those mentioned herein, use the TAP. See TAP Users Guide for additional information.

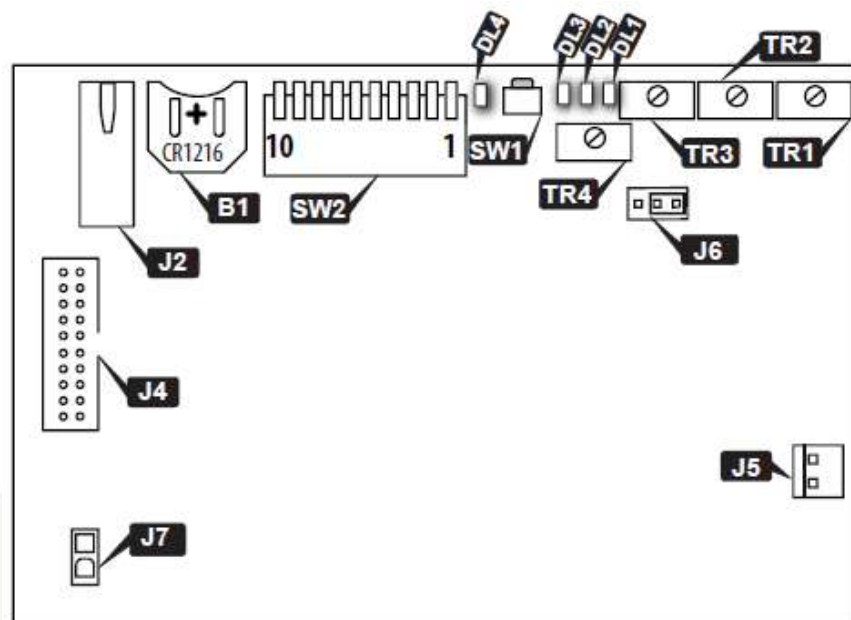



# SET THE DIP SWITCHES ON THE I/O BOARD



- Set the dip switches according to the application.
- Dip switches are used to apply specific functions to the control.
- There are 3 sets of dip switches. TWO 2 - POSITION on the I/O board (DS1 & DS2), and a 10-position at the adjustment board (SW2).

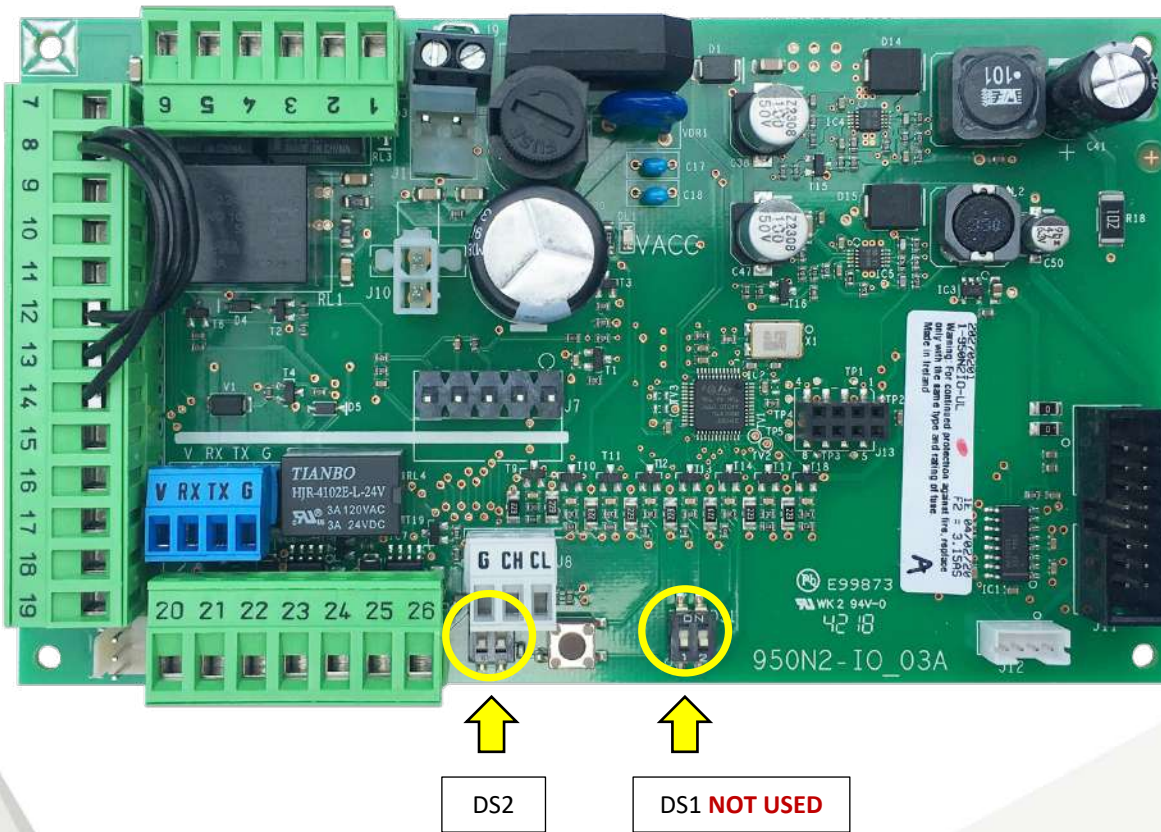

## SET THE DIP SWITCHES ON THE ADJUSTMENT BOARD



- Set the **dip switches** according to the application.

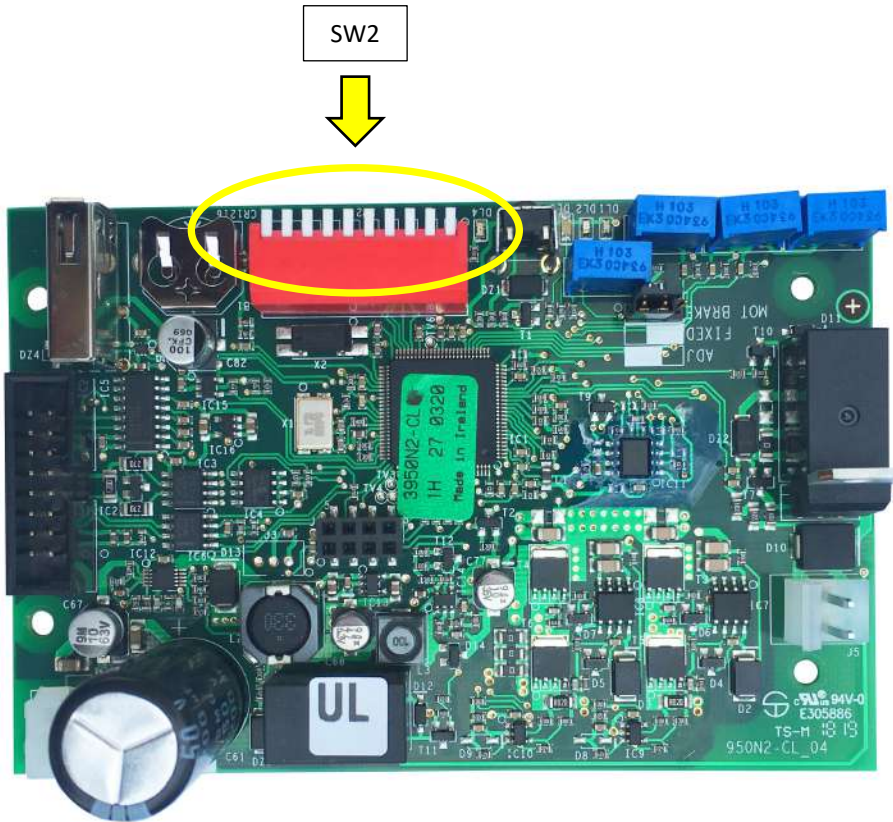

## SET THE DIP SWITCHES ON THE ADJUSTMENT BOARD



	DESCRIPTION	ON	OFF
1	Closed Door Force	Additional force applied while door is in closed position. Be sure to maintain ANSI compliance if using on low energy application. Cannot exceed 30 lbf to get door moving from jamb.	Disabled (Default)
2	Push / Pull Arm	Slide Arm Application. Operator stroke at 90° degrees or less. Visible change in performance may not always be noticeable.	Push Arm Application. Operator stroke 90° or greater. (Default)
3	Night Function (Exit Only)	Allows for one final activation at input 10 when On-Off switch is in OFF (night function) position.	Disabled. The On/Off switch, when OFF, requires manual operation of the door. (Default)
4	Push and Go	Enabled	Disabled (Default)
5	Full Power / Low Energy	Low Energy performance enabled. 5 seconds to open, 7 seconds hold open, 5 seconds to close. Speed & time potentiometers are disabled. Settings are fixed.	Disabled. Control can be adjusted for full power or low energy operation via potentiometers. (Default)
6	Lockout Function	Overhead presence sensor input (17) is inhibited during closing cycle unless input 14 is triggered. Connect COM and Input 14 to NC output of lockout safety beam.	Disabled. Overhead presence sensor input (17) is inhibited during closing cycle. Otherwise, if commanded, it keeps an open door open and a closed door closed. A command at Input 14 will stall the door. (Default).
7	Inhibit at 30 Degrees Before Door Fully Open	Input is disabled at 30 degrees prior to full open door position. Eliminates need for external inhibiting switch.	Stall function remains un-inhibited for full door stroke. (Default)
8	Power Close	Additional closing force applied for final 10 degrees of closing.	Disabled (Default)
9	Assisted Manual Closing***	Enabled assisted closing following a manual opening	Disabled assisted closing following a manual opening
10	FACTORY USE ONLY		

\*\*\* PORTALP USA, Inc. recommends the use of a door-mounted secondary activation device when dip switch 9 is **ON - Enabled**.

# WIRING CONNECTIONS (wiring diagrams are located in the Appendix)



## I/O BOARD CONNECTIONS

	POSITION	FUNCTION	DESCRIPTION
TERMINAL STRIP J5	1	Electric Lock Relay	Common.
	2	Electric Lock Relay	N.O. Dry contact – Contact closes upon activation. May be used for fail-secure locks by routing 1 leg of power through the relay. Relay is triggered by activation inputs 10, 11, or 16. Relay remains energized until door is fully closed again.
	3	Electric Lock Relay	N.C. Dry Contact - Contact opens upon activation. May be used for fail-safe locks by routing 1 leg of power through the relay. Relay is triggered by activation inputs 10, 11, or 16. Relay remains energized until door is fully closed again.
	4	Door Status - Closed	N.O. Contact is closed when door is closed. The contact opens as soon as the door opens.
	5	Door Status – Common	Common contact for door status.
	6	Door Status - Open	N.C. – Contact is closed when door is open. The contact opens as soon as the door starts to close. This input can be used for motor connection at lockout relay when power is looped through, thus switching power on when door is open.
TERMINAL STRIP J6	7	GND	Common GND.
	8	GND	Common GND.
	9	+ 24 VDC	I A. Max Current.
	10	Internal Activation	Requires N.O. Contact between input 10 & COM. Remains capable to activate when dip switch 3 is ON AND On-Off switch is OFF.
	11	External Activation	Requires N.O. Contact between input 11 & COM.
	12	Emergency Closing	Requires N.C. contact between 12 & COM. Upon open contact, door closes and overrides all other inputs. Remains jumpered if input is not used.
	13	Secondary Activation	Requires N.C. contact between 13 & COM. Disabled in full closed position.
	14	“Stall” Safety	Requires N.C. contact between 14 & COM. Upon open contact, (Dip 6 OFF) during opening, door stops, then resumes at reduced speed when input is released.
	15	KEY	KEY INPUT.
	16	Alarm Input	N.O. contact, when closed causes door closing. All inputs inhibited during closed contact (not available on all software versions).
	17	Overhead Presence Sensor Input	Requires N.O. contact between 14 & +24 VDC (input 9). When input is closed it causes an open door to stay open and a closed door to stay closed. Works in conjunction with dip switch #6.
	18	GND	Common GND.
	19	GND	Common GND.
	20	Aux Relay	Auxiliary Relay NOTE: Relay is triggered by input 14.
	21	Aux Relay	Auxiliary Relay N.O.
	22	Aux Relay	Auxiliary Relay N.C.
	23	Alarm Output - Common	Common.
	24	Alarm Output	N.O. output is closed upon closed contact from fire alarm. LED 2 also illuminates.
	25	+ 24 VDC	I A. Max Current.
	26	GND	Common GND.
	<b>INPUTS 27 &amp; 28 NOT USED</b>		

# ADJUSTING THE MECHANICAL DOORSTOP



- **CAUTION – DO NOT REMOVE THE STOPS**
- **IMPORTANT - This step may be optional depending on your application**
- The mechanical stops are located on the top or bottom of the operator, depending on the hand of the door.

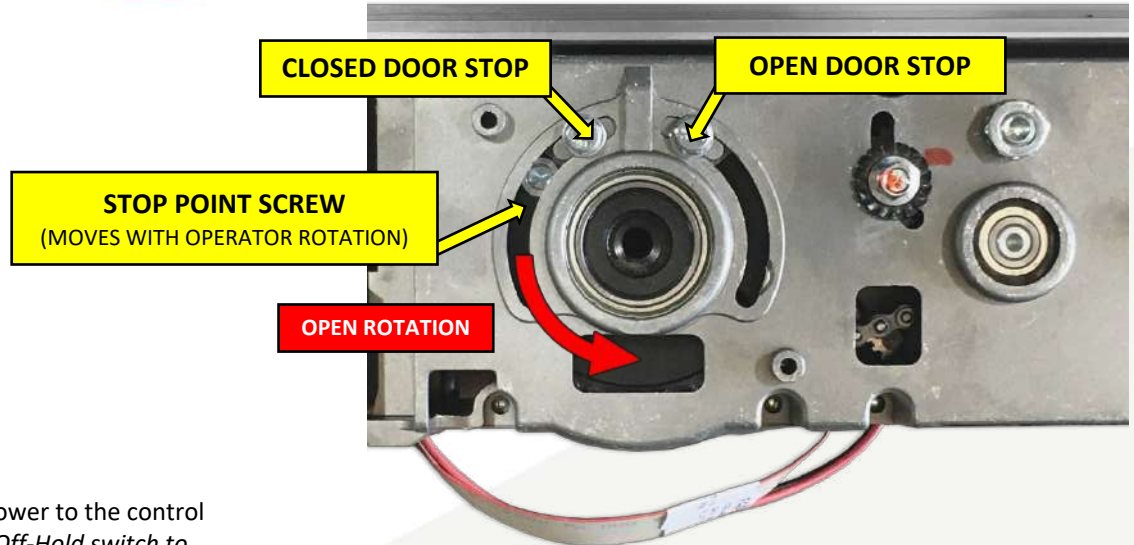
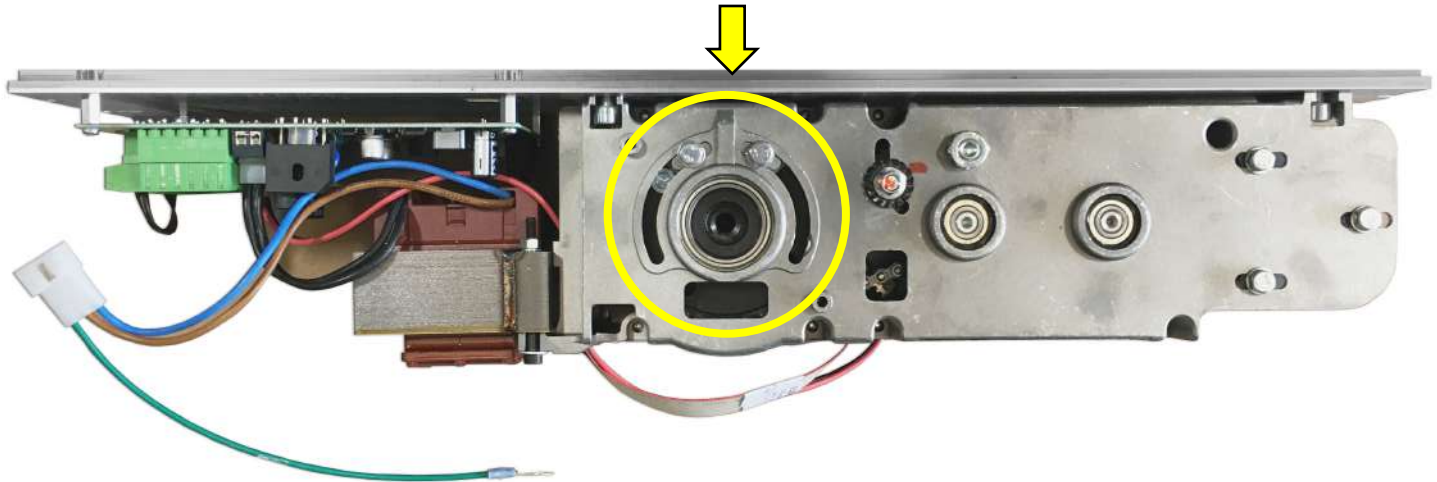

- Apply 120 VAC Main power to the control
  - Place the On-Off-Hold switch to the Hold Open position

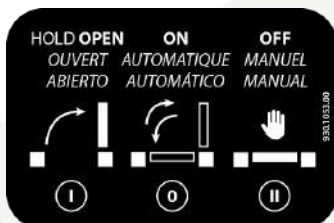

# TROUBLESHOOTING



<p>Door will not open</p>	<ul style="list-style-type: none"> <li>▪ Check On-Off switch for proper position.</li> <li>▪ Check LED status for LD 5, 6, and 7. If any of these LED's are OFF, the door will not open. They require a normally closed circuit.</li> <li>▪ Launch a new setup – see page 26.</li> <li>▪ Check status of emergency input 12.</li> <li>▪ Door has traveled closed past the 0° position.</li> </ul>
<p>Door will not close</p>	<ul style="list-style-type: none"> <li>▪ Check status of LEDs" LD2, 3, 4, 8 on the I/O board.</li> <li>▪ If any of the LED's are ON, check the associated input.</li> </ul>
<p>Door will not reach its fully open or closed position</p>	<ul style="list-style-type: none"> <li>▪ Check the mechanical stops on the operator for proper adjustment.</li> </ul>
<p>Slow flashing red LED (LD2) at the Adjustment Control Board</p>	<ul style="list-style-type: none"> <li>▪ Indicates a possible fault in the control.                         <ul style="list-style-type: none"> <li>○ Check LED status for the other inputs. This will identify if any inputs are currently active.</li> </ul> </li> <li>▪ Indicates a potential faulty setup.                         <ul style="list-style-type: none"> <li>○ Loose or incorrect motor connection.</li> <li>○ Possible loose chain tensioner - refer to Appendix for chain tensioner adjustment procedures.</li> <li>○ Launch a new setup. If problem repeats and there are no other discrepancies noted, replace the operator/control sub-assembly.</li> </ul> </li> </ul>
<p>Door closes too fast at last 5 to 10 degrees of closing</p>	<ul style="list-style-type: none"> <li>• Ensure dip switch 8 is OFF.</li> <li>• Ensure there is no binding of the door as it is closing through the last few degrees of closing. If binding exists (from a tight bottom sweep, for example), correct the condition and then re-launch a new setup.</li> </ul>
<p>Door will not open</p>	<ul style="list-style-type: none"> <li>• Check On-Off switch for proper position.</li> <li>• Check LED status for LD 5, 6, and 7. If any of these LED's are OFF, the door will not open. They require a normally closed circuit.</li> <li>• Launch a new setup – see page 26.</li> <li>• Check status of emergency input 12.</li> <li>• Door has traveled closed past the 0° position.</li> </ul>

## JOB DOCUMENTATION & CLOSEOUT



- Upon completion of the installation, provide the following to the Owner or their assigned agent:
  - Completed & signed work ticket. Be certain to record any serial numbers for items that were replaced.
  - Completed and signed copy of the AAADM inspection form
  - AAADM Owner's Manual
- Additionally, advise the Owner of the work that was performed and ask if there are any other doors that may require service.

## ACCESSORIES

- The BAT Microwave Motion Sensor - PN: 200.1068
- The TORPEDO door-mounted presence sensor - PN: 200.1087
- Spindle Adaptors 20, 35, 50, 80 mm
- TAP Controller – KP EVO – [ADDITIONAL PROGRAMMING/TROUBLE SHOOTING TOOLS](#)

## CUSTOMER SERVICE



**SW 10/19**

FOR MORE INFORMATION PLEASE CONTACT:

**Customer Service:** (412) 823-2537

**E-mail:** [sales@portalp.com](mailto:sales@portalp.com)

# APPENDIX - BOX CONTENT



## OPERATOR SINGLE + PUSH ARM (CA - Clear Anodized)

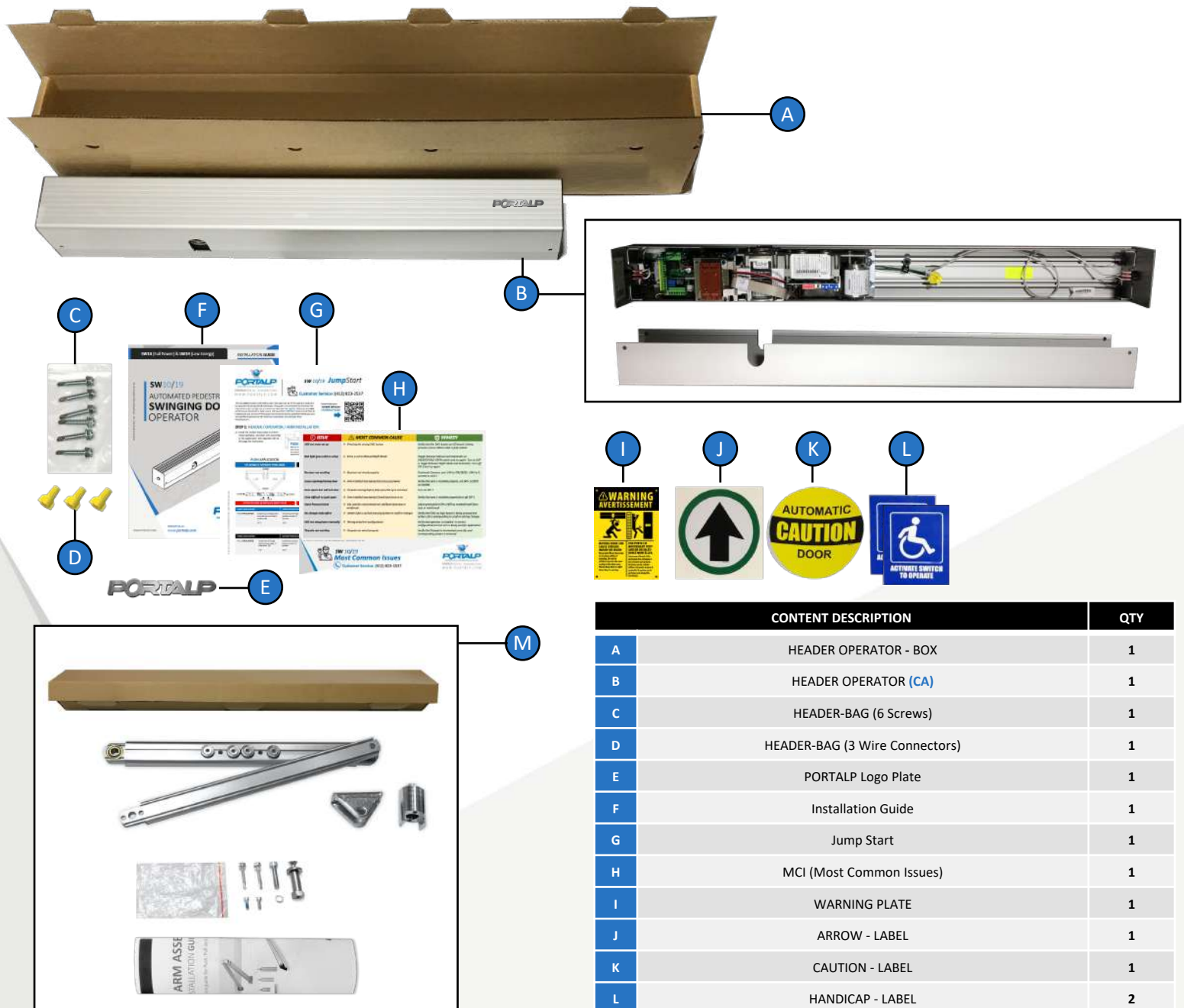

	CONTENT DESCRIPTION	QTY
A	HEADER OPERATOR - BOX	1
B	HEADER OPERATOR (CA)	1
C	HEADER-BAG (6 Screws)	1
D	HEADER-BAG (3 Wire Connectors)	1
E	PORTALP Logo Plate	1
F	Installation Guide	1
G	Jump Start	1
H	MCI (Most Common Issues)	1
I	WARNING PLATE	1
J	ARROW - LABEL	1
K	CAUTION - LABEL	1
L	HANDICAP - LABEL	2
M	PUSH ARM (CA)	1



APPENDIX - BOX CONTENT



PUSH ARM (CA - Clear Anodized)

(CA) QTY: 1 Arm Push-Shaft

(CA) QTY: 1 Push-Arm Extension Short

QTY: 1 SW10 Spindle 35mm

QTY: 1 Hole Shoe

QTY: 1 INSTALLATION GUIDE

QTY: 1 Plastic Bag

PLASTIC BAG CONTENT

QTY: 1 Flat Head M6x16

QTY: 1 Countersunk Finishing Washer

QTY: 1

QTY: 2 nut

QTY: 2 #12-11 x 1 Pan Head Philips Sheet Metal Screw

QTY: 1 Circlip 7mm

QTY: 2 M5x14mm Socket Cap Screw

QTY: 1 M8 X 35 Socket Cap Screw Zinc

M

# APPENDIX - BOX CONTENT



## OPERATOR SINGLE + PUSH ARM (DB - Dark Bronze)

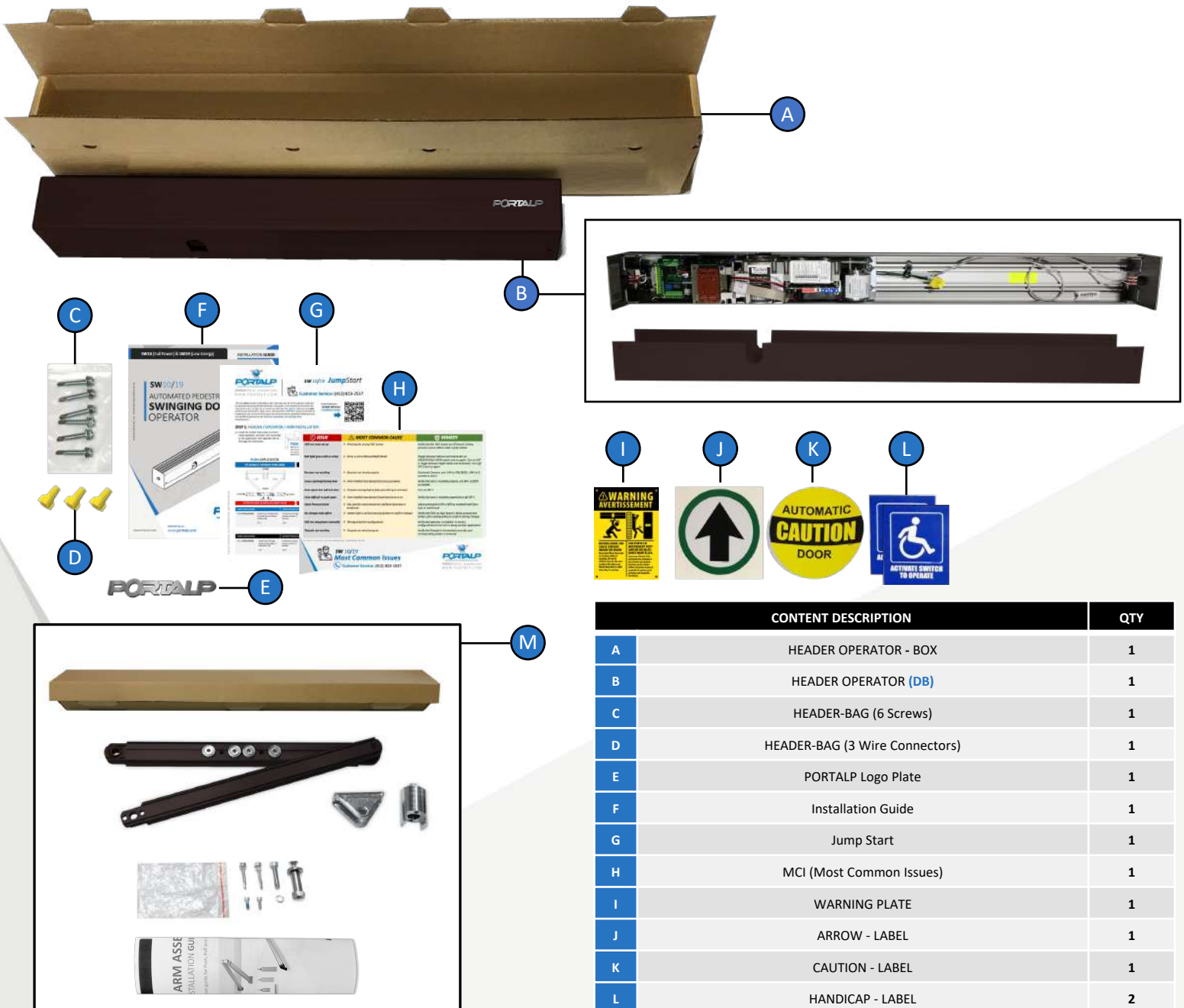

	CONTENT DESCRIPTION	QTY
A	HEADER OPERATOR - BOX	1
B	HEADER OPERATOR (DB)	1
C	HEADER-BAG (6 Screws)	1
D	HEADER-BAG (3 Wire Connectors)	1
E	PORTALP Logo Plate	1
F	Installation Guide	1
G	Jump Start	1
H	MCI (Most Common Issues)	1
I	WARNING PLATE	1
J	ARROW - LABEL	1
K	CAUTION - LABEL	1
L	HANDICAP - LABEL	2
M	PUSH ARM (DB)	1

APPENDIX - BOX CONTENT



PUSH ARM (DB - Dark Bronze)



(DB)  
QTY: 1  
Arm Push-Shaft

(DB)  
QTY: 1  
Push-Arm  
Extension Short

QTY: 1  
SW10 Spindle 35mm



QTY: 1  
Hole Shoe

QTY: 1  
INSTALLATION GUIDE



M



QTY: 1  
Plastic Bag

PLASTIC BAG CONTENT



QTY: 1  
Flat Head  
M6x16

QTY: 1  
Countersunk  
Finishing Washer

QTY: 1

QTY: 2  
nut

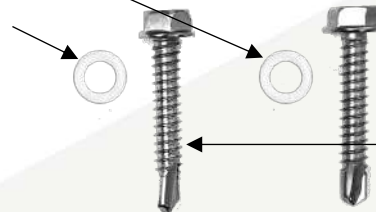

QTY: 2  
#12-11 x 1 Pan Head Philips  
Sheet Metal Screw



QTY: 1  
Circlip 7mm



QTY: 2  
M5x14mm Socket  
Cap Screw



QTY: 1  
M8 X 35 Socket Cap Screw Zinc

# APPENDIX - BOX CONTENT



## OPERATOR SINGLE + PULL ARM (CA - Clear Anodized)



	CONTENT DESCRIPTION	QTY
A	HEADER OPERATOR - BOX	1
B	HEADER OPERATOR (CA)	1
C	HEADER-BAG (6 Screws)	1
D	HEADER-BAG (3 Wire Connectors)	1
E	PORTALP Logo Plate	1
F	Installation Guide	1
G	Jump Start	1
H	MCI (Most Common Issues)	1
I	WARNING PLATE	1
J	ARROW - LABEL	1
K	CAUTION - LABEL	1
L	HANDICAP - LABEL	2
M	PULL ARM (CA)	1

APPENDIX - BOX CONTENT



PULL ARM (CA - Clear Anodized)

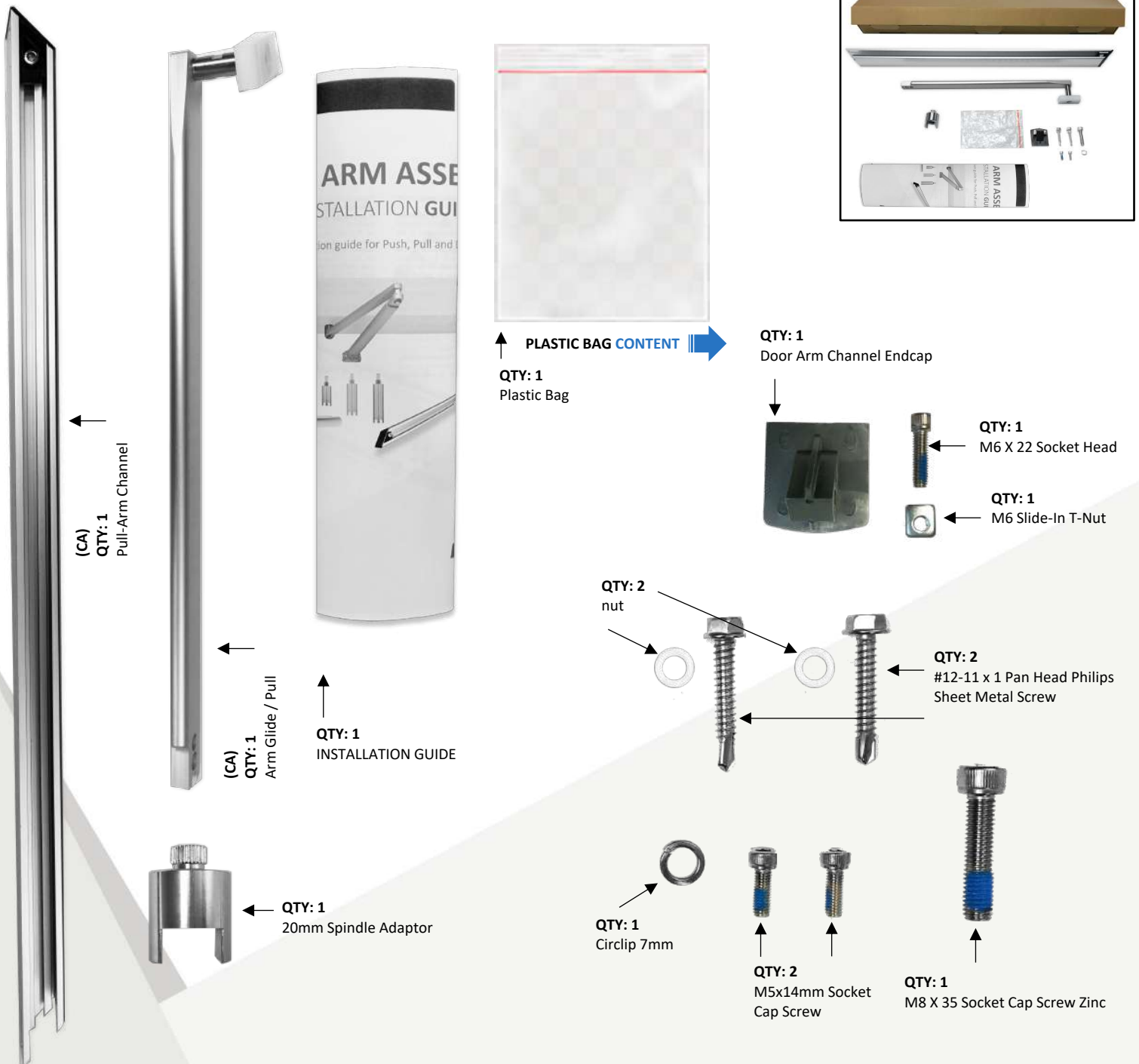

# APPENDIX - BOX CONTENT



## OPERATOR SINGLE + PULL ARM (DB - Dark Bronze)



	CONTENT DESCRIPTION	QTY
A	HEADER OPERATOR - BOX	1
B	HEADER OPERATOR (DB)	1
C	HEADER-BAG (6 Screws)	1
D	HEADER-BAG (3 Wire Connectors)	1
E	PORTALP Logo Plate	1
F	Installation Guide	1
G	Jump Start	1
H	MCI (Most Common Issues)	1
I	WARNING PLATE	1
J	ARROW - LABEL	1
K	CAUTION - LABEL	1
L	HANDICAP - LABEL	2
M	PULL ARM (DB)	1

APPENDIX - BOX CONTENT



PULL ARM (DB - Dark Bronze)

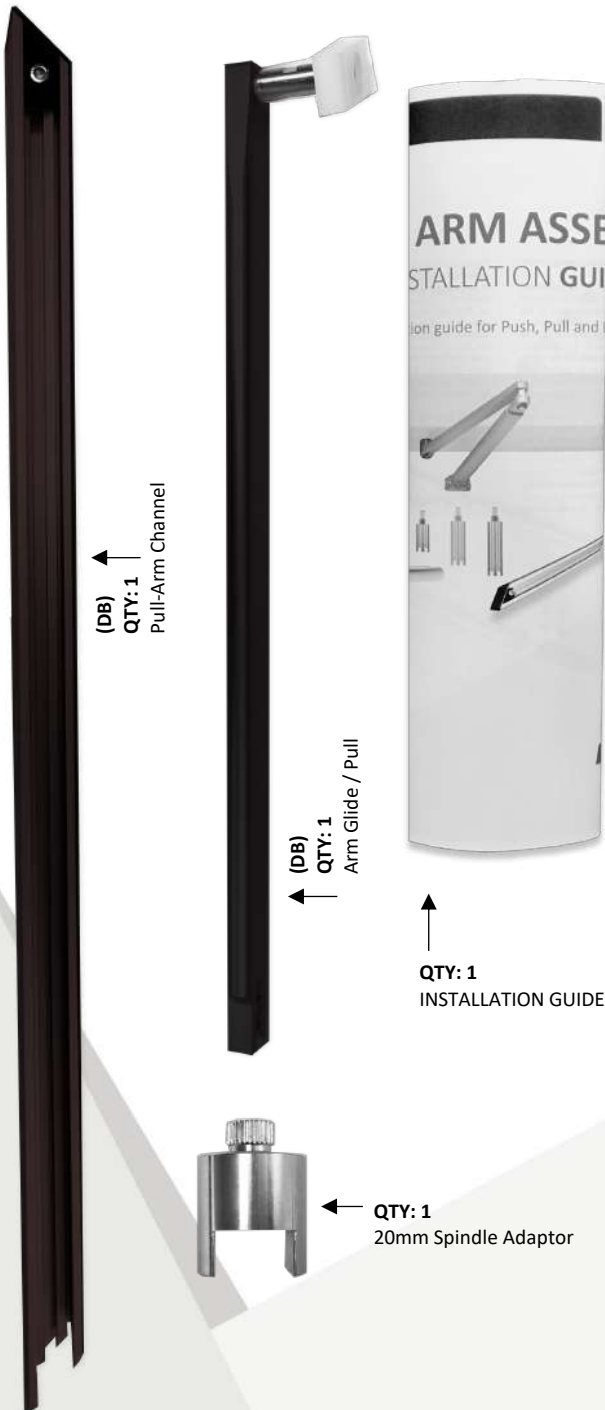

PLASTIC BAG CONTENT

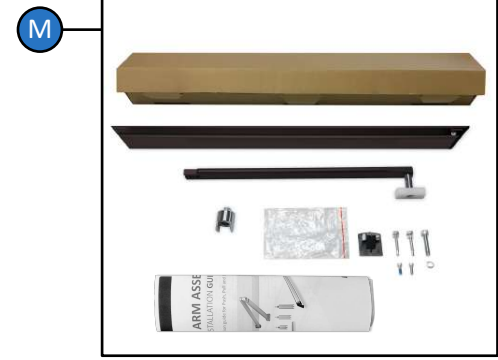

# APPENDIX - BOX CONTENT



## DOUBLE HEADER OPERATOR (CA - Clear Anodized)

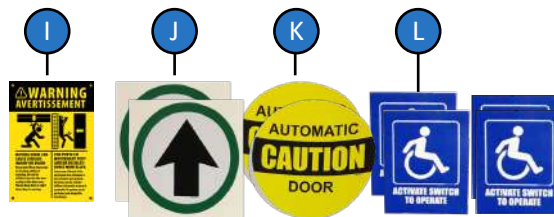
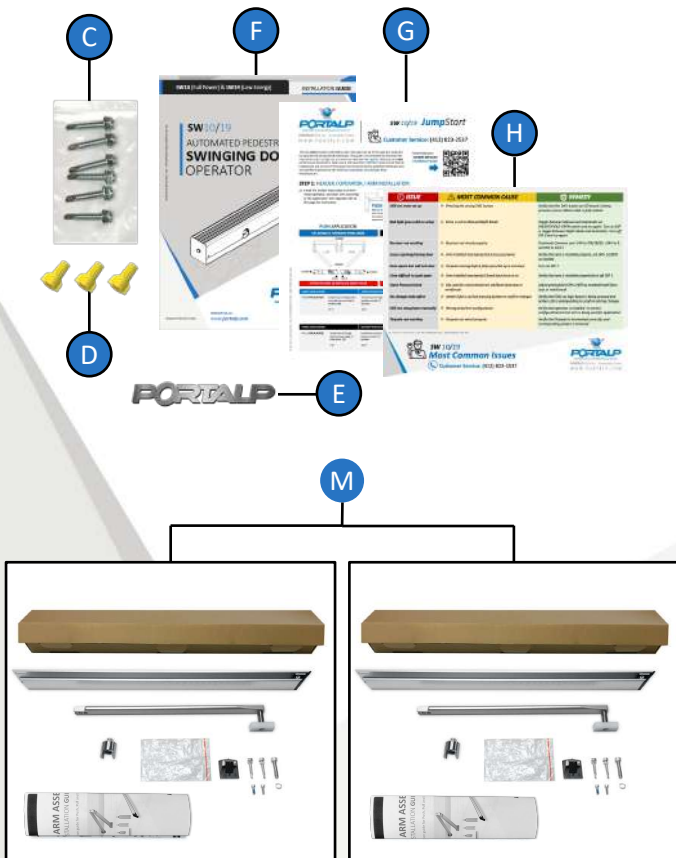
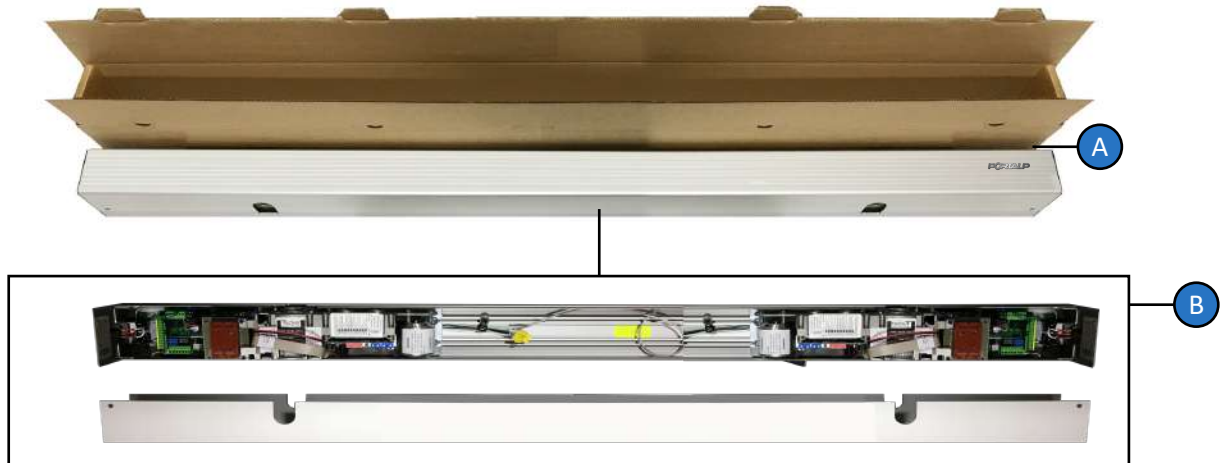

	CONTENT DESCRIPTION	QTY
A	HEADER OPERATOR - BOX	1
B	DOUBLE HEADER OPERATOR (CA)	1
C	HEADER-BAG (6 Screws)	1
D	HEADER-BAG (3 Wire Connectors)	1
E	PORTALP Logo Plate	1
F	Installation Guide	1
G	Jump Start	1
H	MCI (Most Common Issues)	1
I	WARNING PLATE	1
J	ARROW - LABEL	2
K	CAUTION - LABEL	2
L	HANDICAP - LABEL	4
M	PULL ARM (CA)	2



APPENDIX - BOX CONTENT



PULL ARM (CA - Clear Anodized)

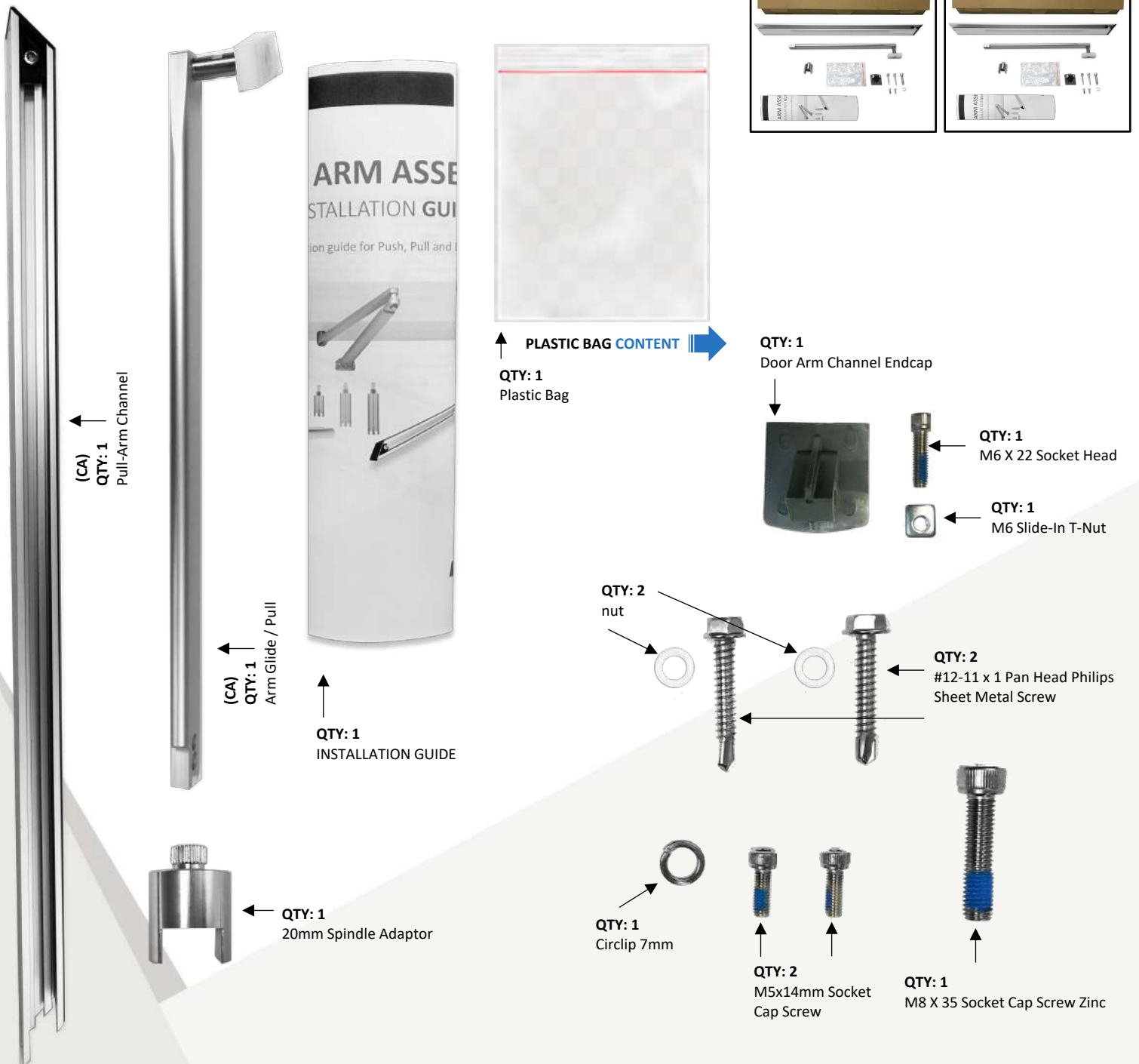

APPENDIX - BOX CONTENT



PULL ARM (CA - Clear Anodized)

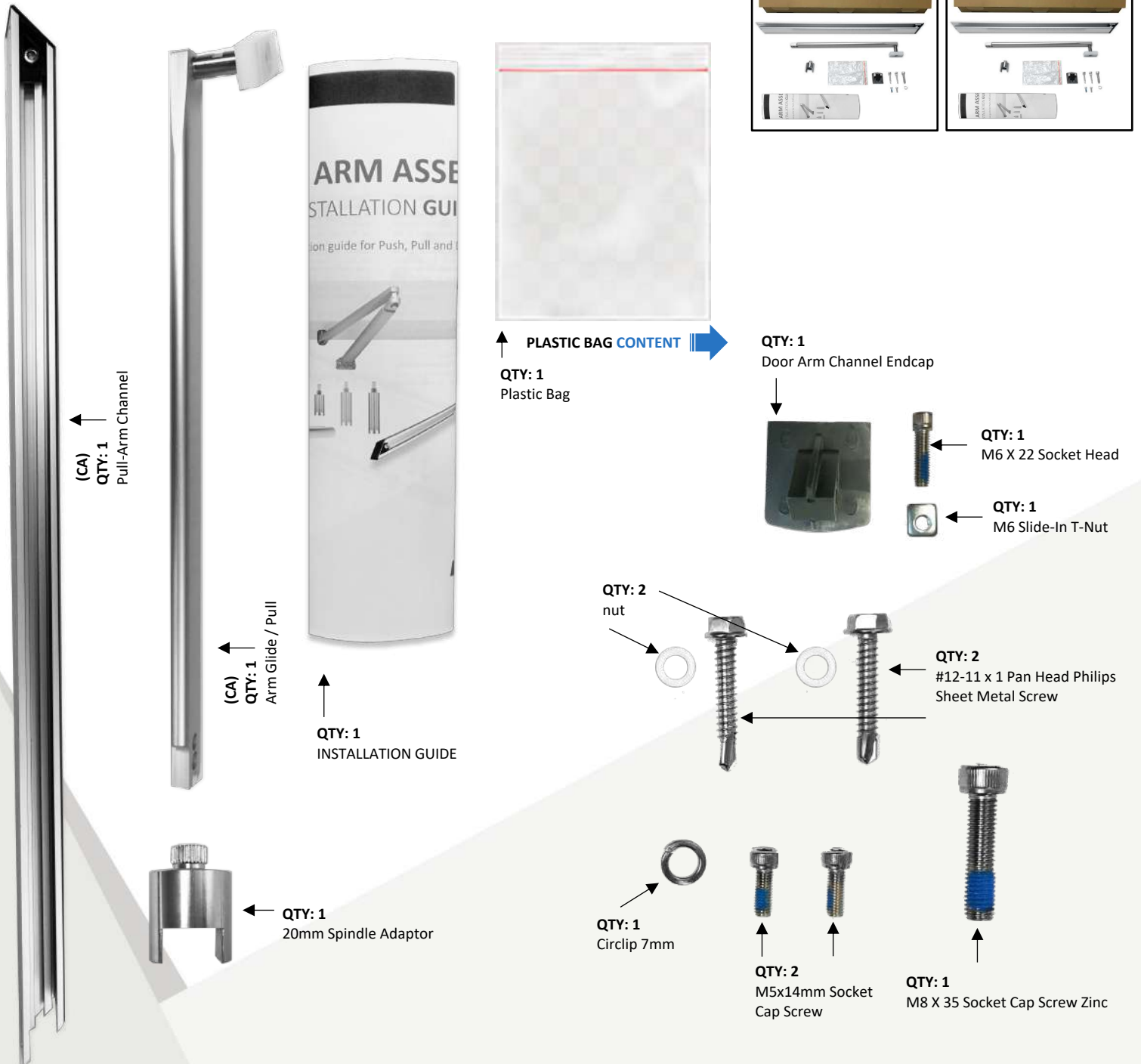

# APPENDIX - BOX CONTENT



## DOUBLE HEADER OPERATOR (DB - Dark Bronze)



	CONTENT DESCRIPTION	QTY
A	HEADER OPERATOR - BOX	1
B	DOUBLE HEADER OPERATOR (DB)	1
C	HEADER-BAG (6 Screws)	1
D	HEADER-BAG (3 Wire Connectors)	1
E	PORTALP Logo Plate	1
F	Installation Guide	1
G	Jump Start	1
H	MCI (Most Common Issues)	1
I	WARNING PLATE	1
J	ARROW - LABEL	2
K	CAUTION - LABEL	2
L	HANDICAP - LABEL	4
M	PULL ARM (DB)	2

APPENDIX - BOX CONTENT



PULL ARM (DB - Dark Bronze)

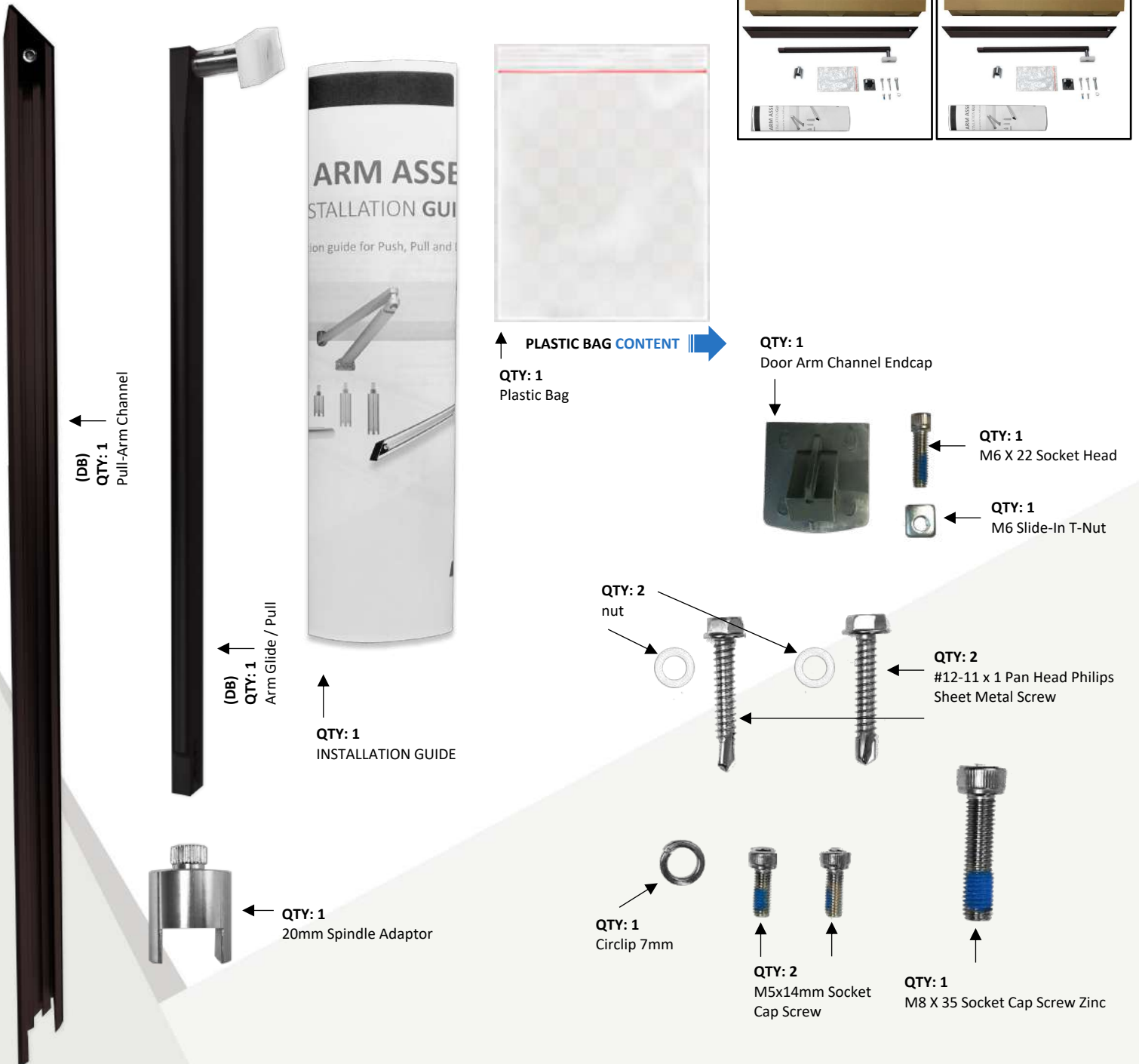

APPENDIX - BOX CONTENT



PULL ARM (DB - Dark Bronze)

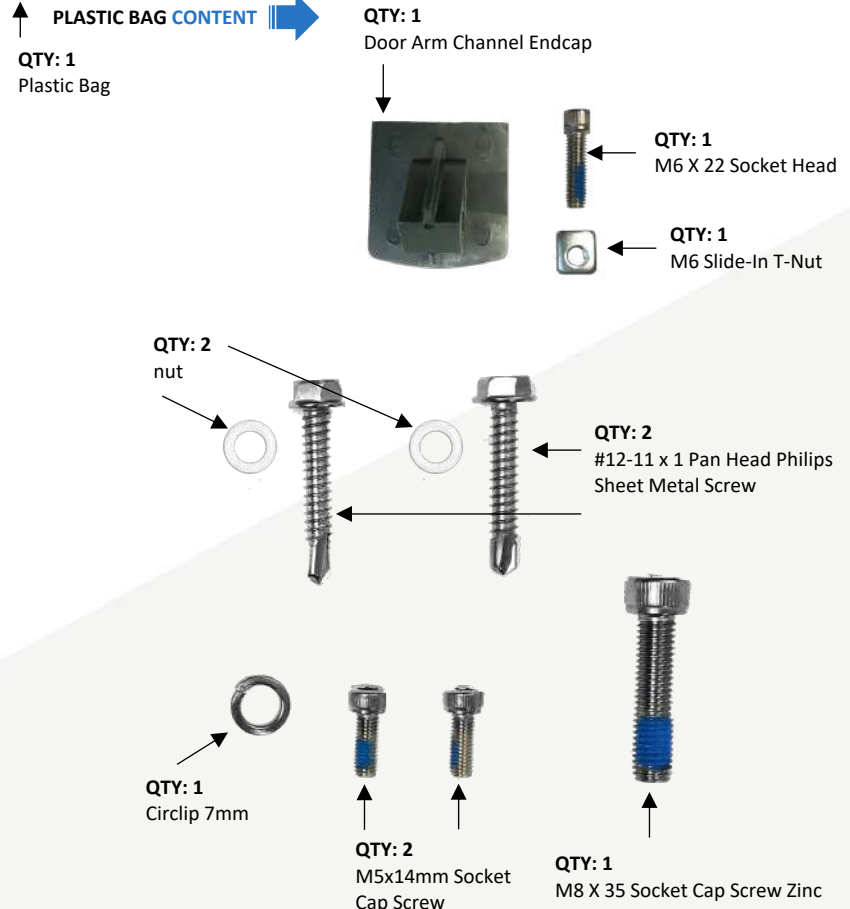

## APPENDIX - WIRING DIAGRAMS



## LOW ENERGY APPLICATION: PUSH PLATES WITH APPROACH SIDE DOOR-MOUNTED SENSOR

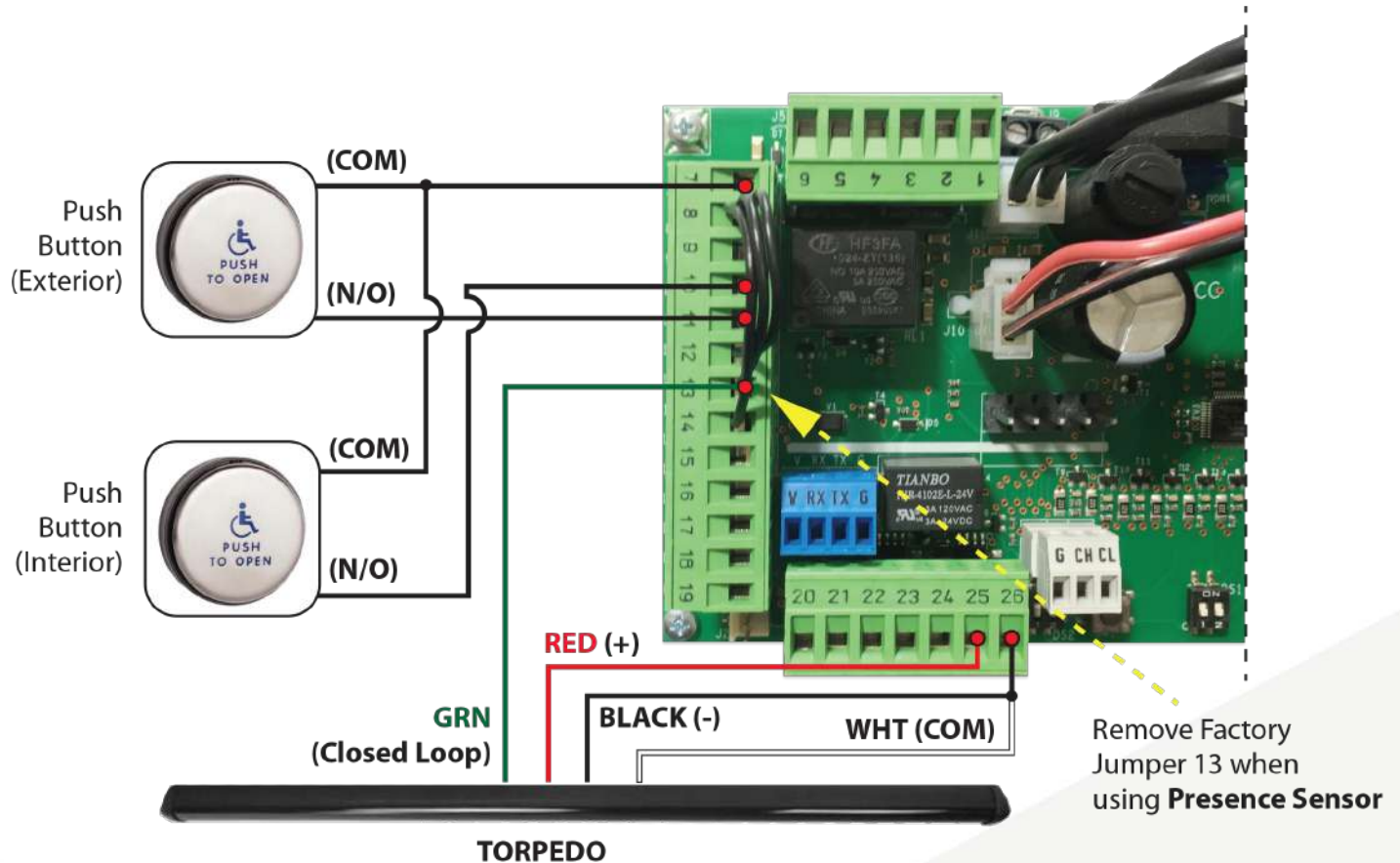

- Non-Swing Side (approach) door-mounted sensor is wired into the secondary activation input (13) at the I/O board. It is a normally closed circuit. Remove factory jumper on terminal 13.
- Door-mounted sensor will cause re-activation when in detection during the closing cycle.
- Secondary activation input is disabled at the full closed door position.
- Jumpers must be installed between terminal 8 and 12 & 14 if those inputs are not required for the application. If they are used for the application, they must be connected to a N.C. circuit.

## APPENDIX - WIRING DIAGRAMS



## SIMULTANEOUS PAIRS

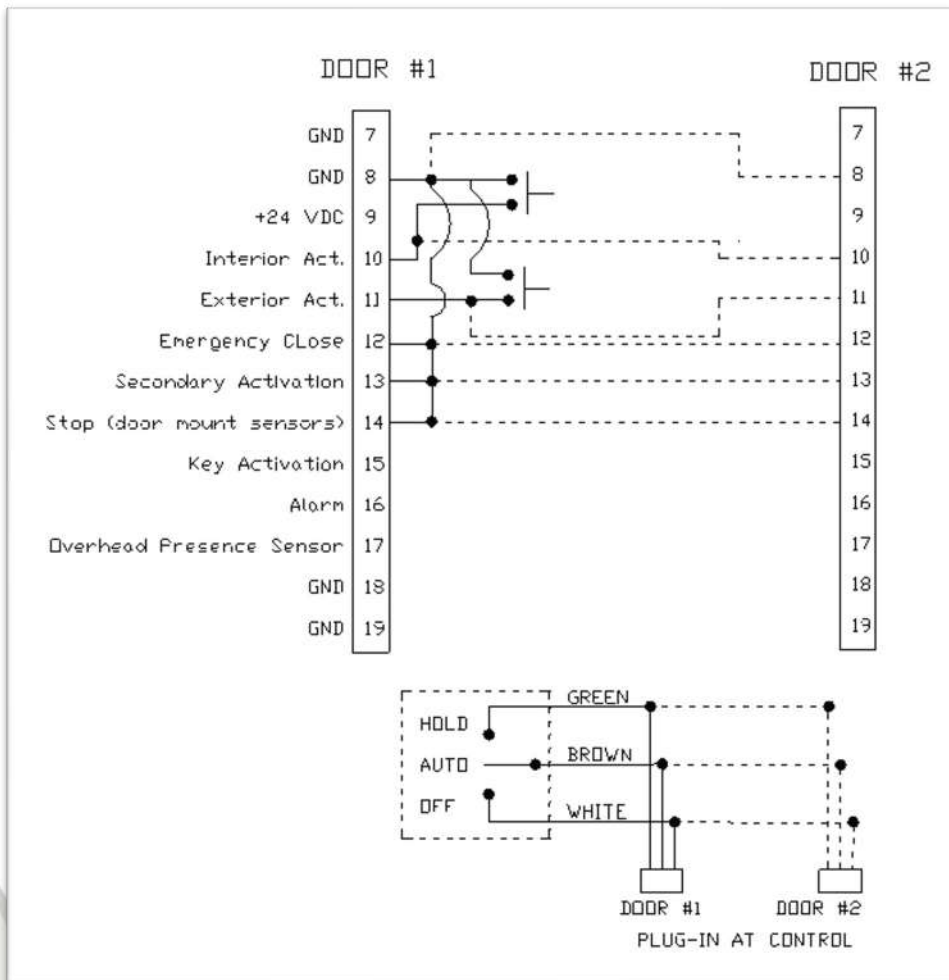

- When wiring controls for use as a simultaneous pair, all required inputs need to be sync'd (connected) between Door #1 and Door #2 (shown as dotted lines in above diagram).
- Example shown above: Push plates are connected to inputs 8, 10 and 11 at door #1 and are connected via sync line to Door #2.
- When using pairs of controls, N.C. inputs 12, 13 and 14 may be sync'd to each other, OR each control may have its own jumpers installed. If any of these inputs are required for the application, the jumper will be removed for the respective input – in place of the jumper, a N.C. switching circuit will be connected to Door #1, and a sync line will be connected to Door #2.
- For simultaneous pairs, PORTALP provides a dual harness for the On-Off-Hold switch. Each plug-in connector for the control is wired in parallel to the On-Off-Hold switch located in the header end-cap. One switch will control both doors.
- All control adjustments (speed & time delay) must be made independently at each control.
- All dip switches at each control must be set independently and must match between controls.
- When using the TAP programmer, settings must be made independently at each control and must match between controls.

# APPENDIX - ELECTRIC LOCK APPLICATION



## 1. Wireless push plates with electric strike.

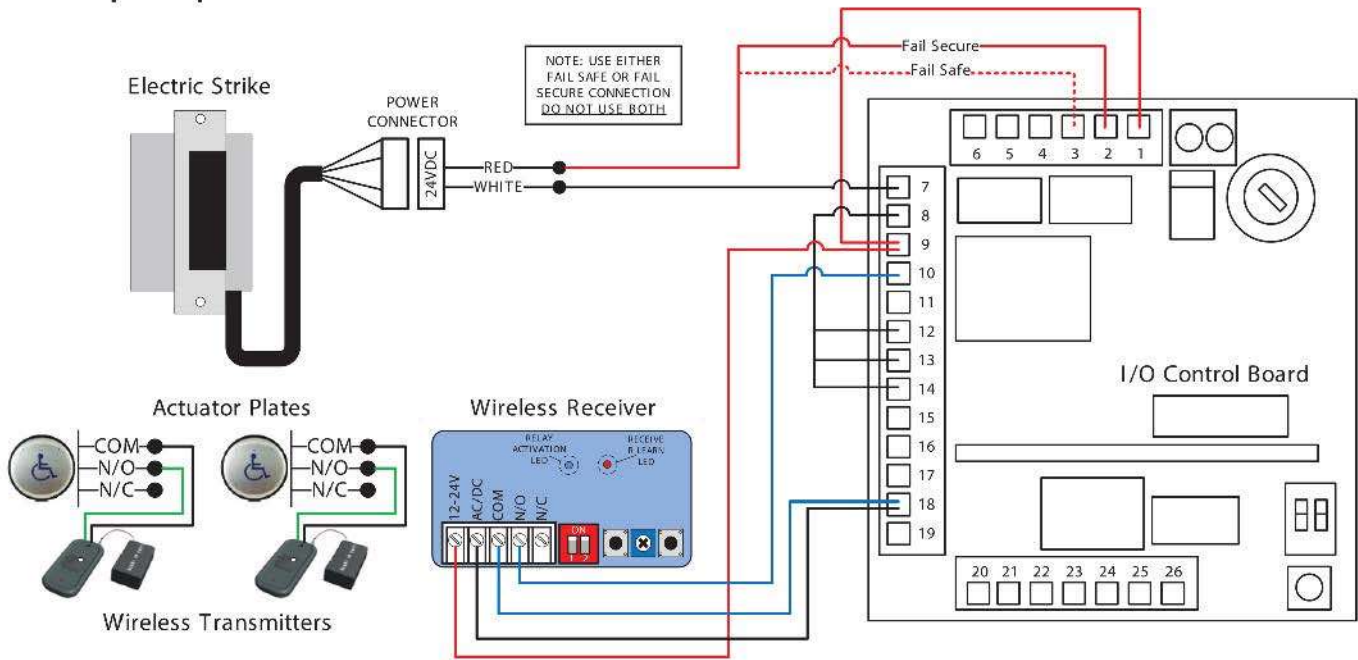



## APPENDIX – SW10 PAIR WITH THE BAT + TORPEDO + BEA BODUGUARD

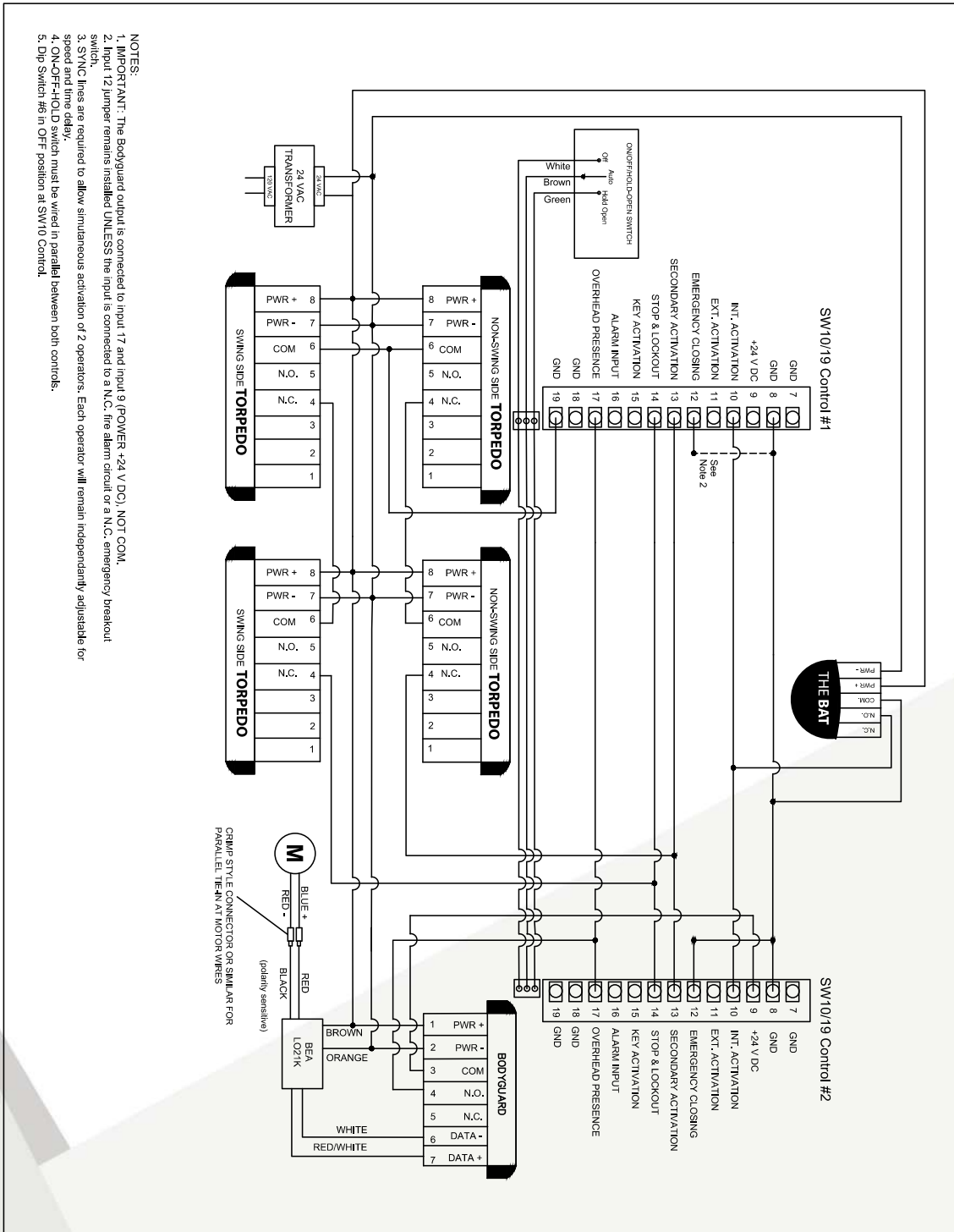

- NOTES:**
1. **IMPORTANT:** The Bodyguard output is connected to input 17 and input 9 (POWER +24 V DC), NOT COM.
  2. Input 12 jumper remains installed UNLESS the input is connected to a N.C. fire alarm circuit or a N.C. emergency/breakout switch.
  3. SYNC lines are required to allow simultaneous activation of 2 operators. Each operator will remain independently adjustable for speed and time delay.
  4. ON-OFF-HOLD switch must be wired in parallel between both controls.
  5. Dip Switch #6 in OFF position at SW10 Control.

APPENDIX – SW10 SINGLE/PAIR WITH THE BAT + BEA LZR MICROSCAN

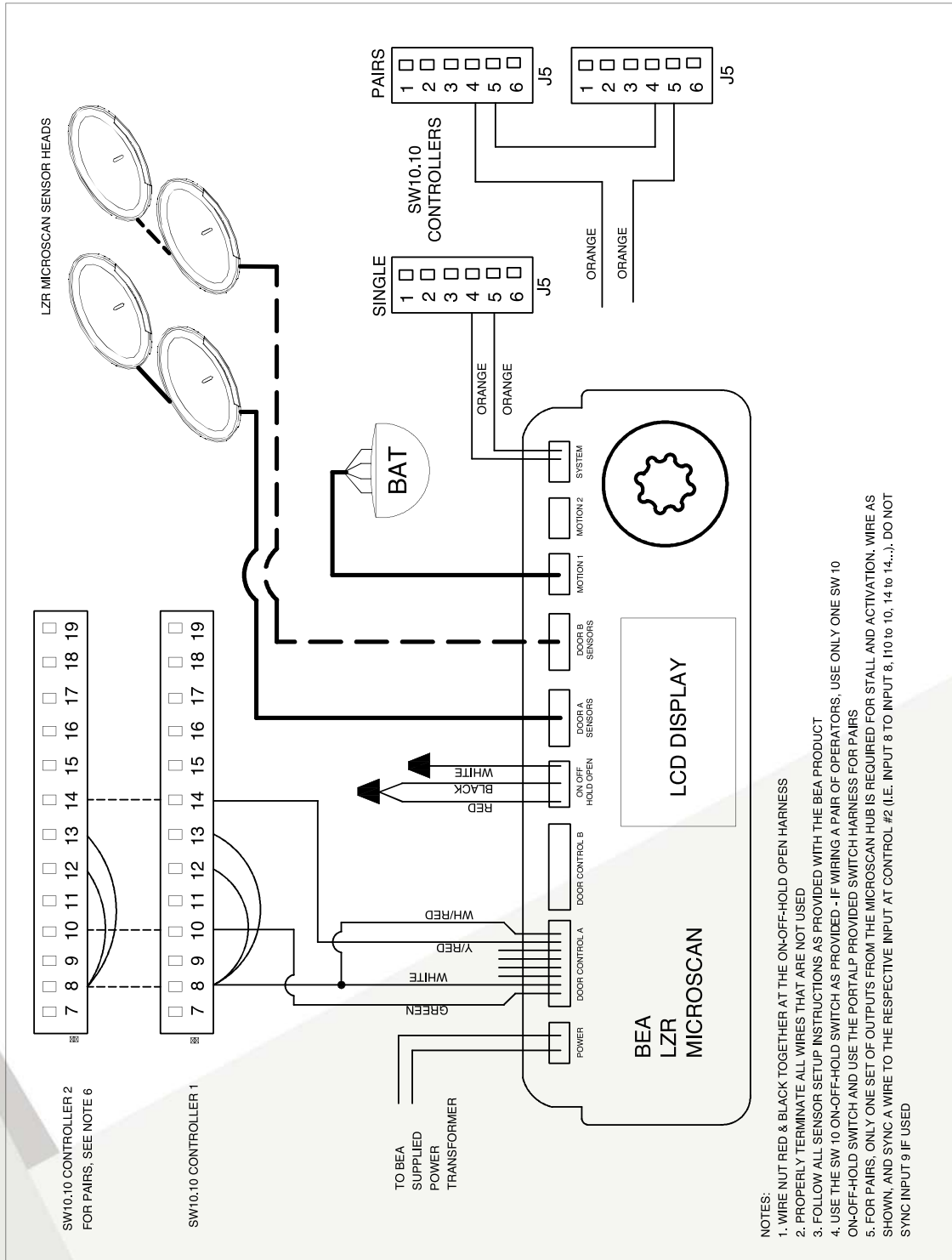

APPENDIX - SW10 SINGLE WITH THE BAT + BEA BODUGUARD

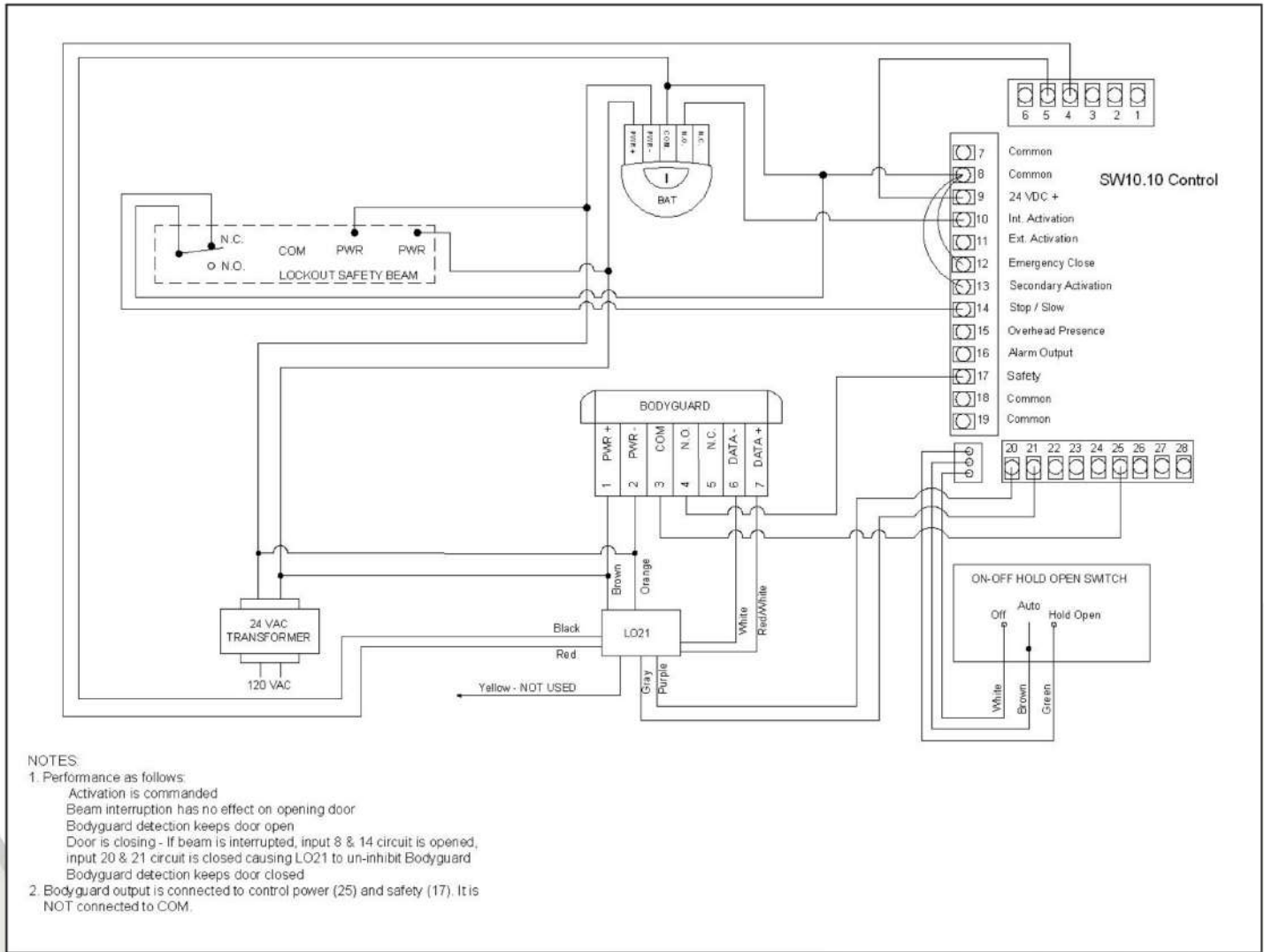

NOTES:

- Performance as follows:  
 Activation is commanded  
 Beam interruption has no effect on opening door  
 Bodyguard detection keeps door open  
 Door is closing - If beam is interrupted, input 8 & 14 circuit is opened, input 20 & 21 circuit is closed causing LO21 to un-inhibit Bodyguard  
 Bodyguard detection keeps door closed
- Bodyguard output is connected to control power (25) and safety (17). It is NOT connected to COM.

## APPENDIX - FIRE RATED DOOR APPLICATION



- Perform the installation according to the instructions outlined in this manual. Additionally, ensure the following conditions have been met:

- When attaching the door arm to the door, use steel binding posts (Hex Bolts) to attach. Do NOT use sheet metal screws into the face of the door. The door arm bracket must be through-bolted.

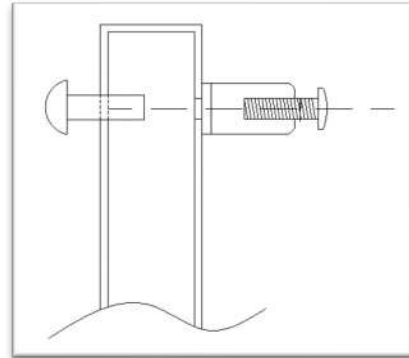

- When attaching the header to the hollow metal door frame, ensure there are 5 attaching screws spaced equally apart. They should be #12 sheet metal type screws.

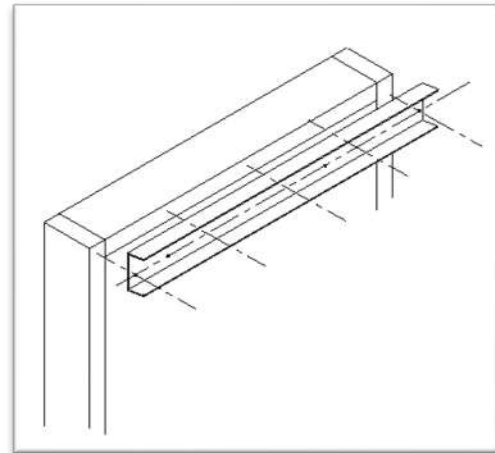

- Fire rated power operated doors must close and latch during a fire alarm condition. Ensure proper procedures have been followed to allow a main power disconnect during a fire alarm condition. Always check to ensure compliance to local building codes.
  - Upon job completion, always perform a functional test to ensure that the door(s) close and latch following a power loss.
- Other hardware may be required to complete the installation. For example, for pairs of doors, if an Astragal is installed, a mechanical door coordinator may be required to ensure a proper coordinated closing during a power loss.
- Only fire rated hardware shall be used on a fire rated door & frame assembly.
- Ensure the Tucker SW10/19 that is being installed has the proper fire rated label applied to the header.

## APPENDIX - TAP PROGRAMMING DEVICE - KP evo



**+ OPTIONAL**

**Please note**, some functions of the SW10/19 controller require the use of a hand-held “TAP” programming device. The following functions require use of this device for programming:

- ✓ Logic Assignment For Inputs
- ✓ Logic Assignment For Outputs
- ✓ Opening & Closing Acceleration
- ✓ Opening & Closing Deceleration
- ✓ Opening & Closing Strength (obstruction force)
- ✓ Opening & Closing Strength Duration (time duration for obstruction force)
- ✓ Night-Time Hold Open Time
- ✓ Delay On Activation (up to 4 seconds)
- ✓ Electric Lock Interfacing
- ✓ Master/Slave Configuration
- ✓ Cycle Count – Maintenance Reset
- ✓ 7-Day Programmable Timer (With Daylight Savings Time)
- ✓ Troubleshooting & Data

